



**Marion County
Board of County Commissioners**

Growth Services • Planning & Zoning

2710 E. Silver Springs Blvd.
Ocala, FL 34470
Phone: 352-438-2600
Fax: 352-438-2601

SPECIAL USE PERMIT APPLICATION – 2025

The undersigned hereby requests a Special Use Permit in accordance with Marion County Land Development Code, Articles 2 and 4, for the purpose of: _____
Telecommunication Tower Site

Parcel Account Number(s): 32651-000-01

Property/Site Address: no street address; SE 24th St., Silver Springs

Future Land Use Designations: RL **Zoning Classification:** R-4

Current Property Use: Vacant **Total Acreage:** 63.90 ac m.o.l.

Request for a reasonable accommodation Yes / No (See checklist item #7 on page 3)

Request for a special use listed in checklist item #4? Yes / No (See page 3)

Each property owner(s) **MUST** sign this application or provide written authorization naming an Applicant or Agent below to act on his/her behalf. Please **print** all information, except for the Owner and Applicant/Agent signature. If multiple Owners or Applicants/Agents, please use additional pages.

Property Owner Name (print) Martin R. Helgerson Trust	Applicant or Agent Name (print) Applicant: Skyway Towers, LLC Agent: Jaime Maier, Esq. / Hill Ward Henderson, P.A.
Mailing Address 5750 NE 36th Ave. Rd.	Mailing Address 101 E. Kennedy Blvd., Ste. 3700
City, State, Zip Ocala, FL 34479	City, State, Zip Tampa, FL 33602
Phone Number (include area code) Same as applicant/agent	Phone Number (include area code) 813-506-5184
E-Mail Address Same as applicant/agent	E-Mail Address Jaime.Maier@hwlaw.com
Signature* 	Signature*
Printed Name and Title of Authorized Signer (for corporate, trust & other entities) Martin R. Helgerson as Trustee of Martin R. Helgerson Trust	Printed Name and Title of Authorized Signer (for corporate, trust & other entities) Jaime Maier, Esq., as Agent for applicant

*By signing this application, the Owner, Applicant, and/or Agent hereby authorizes Growth Services to enter onto, inspect, and traverse the property indicated above, to the extent Growth Services deems necessary, for the purposes of assessing this application and inspecting for compliance with County ordinances and any applicable permits.

STAFF/OFFICE USE ONLY

LDC Section that allows proposed Special Use:

Project No.:	Application Request No.:	Code Case No.:
Rcvd by:	Rcvd Date: / /	Time:
		PZ Case No.:

Please note: If approved, the Special Use Permit will **not** become effective until 14 days **after** the final decision is made by the Marion County Board of County Commissioners and any applicable appeal period concludes. The Owner, Applicant or Agent must be present at all pertinent public hearings to represent this application. If no representative is present and the board requires additional information, the request may be postponed or denied. Notice of said hearing will be mailed to the above-listed address(es). All information given by the Applicant or Agent must be correct and legible to be processed. The filing fee is non-refundable. For more information, please contact the Growth Services Zoning Division at 352-438-2675.

List of Submitted Materials for Special Use Permit:

- Collocation Agreement Letter
- Fall Zone Letter
- Justification Narrative and Findings of Fact
- Conceptual Plan and Elevations
- Propagation Maps
- Deed
- Application Form and Checklist
- Zoning, Future Land Use, Existing Use, and Aerials Maps
- FAA and FCC Documentation
- RF Compliance Letter
- Geotech Report
- Search Ring and Tower Inventory
- Lease with Site Owner
- Airport Location Map

Wireless Communication Tower

Folio 32651-000-01 – Silver Springs

Findings of Fact:

1: A private access easement for use of the tower is part of the leased area, as depicted on the site plan, and connecting to SE 20th Street.

2: Access to the tower after construction will occur a maximum of once a month, as this is an unmanned tower, therefore parking/loading areas are not relevant and similarly this passive use will not produce parking or loading related noise or other impacts to the surrounding area.

3: The cell tower use will not produce waste, as an unmanned and passive use.

4: Water and sewer connections are not required for the cell tower use.

5: There is significant existing tree coverage and vegetation on the site, which will remain on the site aside from necessary clearing for the compound area and access; this existing vegetation will serve as a natural dense buffer/screening area.

6: The only signage proposed is that required for cell towers under the Code and/or applicable federal law. Similarly, lighting will only be provided if required by law.

7: The lease area is depicted in the survey and site plan materials included with this application; the remainder of the site is vacant. As described in the attached supplemental project narrative, relief from the separation standards for cell towers to residentially-zoned property is required due to the fact that the Site includes an irregular “pocket” where Marion County- owned land is surrounded by a portion of the Site and therefore the proposed tower is less than 100% of its height away from that land. Although zoned residential (R-4) it appears to be utilized as a utility building.

8: As described in the attached supplemental project narrative, the surrounding area is primarily small-lot residential land, with the Site being a large undeveloped property that provides for a natural separation from the surroundings due to the proposed location of the tower within the Site. The proposed use of a cell tower is a passive use that will be largely screened by the site’s tree canopy and vegetation, and the line of sight on the ground to the proposed tower will be significantly broken up by the tree coverage in the greater area as well. The proposed cell tower will provide needed coverage to an area that is currently underserved by cell provider coverage.

9: Please see the attached supplemental project narrative, which specifically addresses the cell tower Code section of the Marion County Land Development Code. The applicant is

Wireless Communication Tower

Folio 32651-000-01 – Silver Springs

prepared to meet the requirements as described therein, including the permissible request for relief from separation from R-4 zoning, due to the irregular shape of the Site and the utility use of that R-4 zoned County lot.

Supplemental Project/Code Compliance Narrative:

The Applicant, Skyway Towers, LLC, seeks to construct a wireless communication tower on the Site in the County. The proposed tower is a 125' monopole tower, with an additional 4' for a lightning rod, and compound space for collocation of multiple cell service providers.

The surrounding area is characterized by a significant amount of tree coverage, and residential and agricultural uses, and vacant land. The Site is zoned R-4, where a tower is permitted by Special Use under the Code.

The proposed tower addresses the applicable sections of Sec. 4.3.25 of the Land Development Code as follows:

4.3.25.D:

- 1) The tower is within the permitted maximum height of the Code under a Special Use permit, and as described, there is significant tree coverage around the perimeter of the Site and in the surrounding area which significantly reduces line of sight visibility of the proposed tower from the ground. The proposed access to the tower compound will be via an access easement through the Site to SE 20th St. There are no nearby structures of sufficient height or capacity on which to locate the multiple providers' worth of antenna and equipment that will be located on the proposed tower Site and still maintain the same level of coverage proposed by the tower. As evident from the propagation maps included with this application, a gap in coverage exists in the projected coverage area, which is remedied by the proposed tower.
- 2) As described, there is a significant amount of tree coverage between the proposed tower location and any residential uses in the surrounding area. As described further herein, the proposed tower location is within the required distance separation amounts required by the Code from residential structures, at well over 150% of tower-height from the nearest structure.

Wireless Communication Tower

Folio 32651-000-01 – Silver Springs

- 3) There is no potential conflict with airport flight paths, and FAA-required lighting will be provided.
- 4) As described, the existing trees around the Site provide a significant line of sight buffer from immediately adjacent and nearby properties.
- 5) Please see the search radius for the proposed tower included with this application, which included no existing structure with height or capacity to locate the service providers' antenna.

4.3.25.E:

- 1) The tower is set back appropriately from surrounding uses, and a certified fall radius letter is included with this application. The tower's distance from any of the closest residential structures well exceeds 150% of the tower's height as required. The proposed tower requires relief from being located 100% of its height away from a residential zoning district, because both the Site on which the tower is proposed to be located, and the adjacent County-owned land which is surrounded by the irregular Site as a sort of "pocket", are zoned R-4. The tower is about $\frac{3}{4}$ of the necessary distance from the corner of that adjacent R-4 property, which appears to be utilized as a County utility building. Therefore, the request is justified as the Fall Zone letter provides that the tower, in the unlikely event it were to collapse, will fall within the leased area which is well within the Site's boundaries, and the R-4 land from which the distance waiver is sought is a utility use, not a residential one.
- 2) The tower is designed and intended for collocation. Please see the collocation commitment letter included with this submittal.
- 3) Tower clustering is not proposed.
- 4) The existing mature tree growth on and around the property shall be preserved and the Applicant requests to utilize same in lieu of planting landscaping.
- 5) The tower lighting will comply with FAA requirements.
- 6) The tower will be of a galvanized steel finish.
- 7) The tower compound is not adjacent to any buildings.
- 8) Antennas are to be installed on the tower. Please see the tower specs and elevations included with this submittal.
- 9) Only required safety and FCC signage will be located on the tower compound.
- 10) The tower compound will be fenced.

Wireless Communication Tower

Folio 32651-000-01 – Silver Springs

- 11) The Applicant currently has one other constructed tower in Marion County, located at folio 36882-000-00.
- 12) The tower will comply with FAA, FCC, and other applicable federal standards.
- 13) The tower shall satisfy building code standards.
- 14) The Applicant is prepared to comply with public notice requirements.

4.3.25.F:

- 1) The Applicant has prepared and submitted a site plan with all necessary information.
- 2) The proposed height of the tower per the site plan is 125', with additional 4' for a lightning rod.
- 3) A map series including aerial views of the surrounding area and zoning districts of the surrounding area are included with this application.
- 4) A tower search radius indicating all towers within 3.0 miles is included, which is greater than the distance of the Applicant's search ring of .5 miles. Please note that registered potential tower labeled 1328959, which is approximately 1 mile from the Site, does not appear to have actually been built. The Applicant's contact information (Skyway Towers, LLC) is on the site plan.
- 5) FCC and FAA documentation is included.
- 6) There were no candidate existing towers within the search ring of .5 miles to contact. The surrounding area within the .5 mile search ring consists predominantly of small lots which are considerably less conducive to a tower compound and separation than the Site which is the largest in the immediate surroundings by far. Accordingly, only the subject Site resulted in a viable candidacy for a tower location. The Site is a good candidate within the pattern of the area due to its ability to provide a distance of over 150% of tower-height from the nearest residential structure, and significant existing vegetation and tree canopy.
- 7) The technical details of the tower are included in the site plan sheets and tower engineering report.
- 8) A statement from an RF engineer is included.
- 9) A Geotechnical engineering report is provided.
- 10) None of the specified materials are present on site.
- 11) The Applicant will provide 20 written copies of any expert reports that may be produced for the hearing.
- 12) The Applicant is prepared to pay all associated fees.

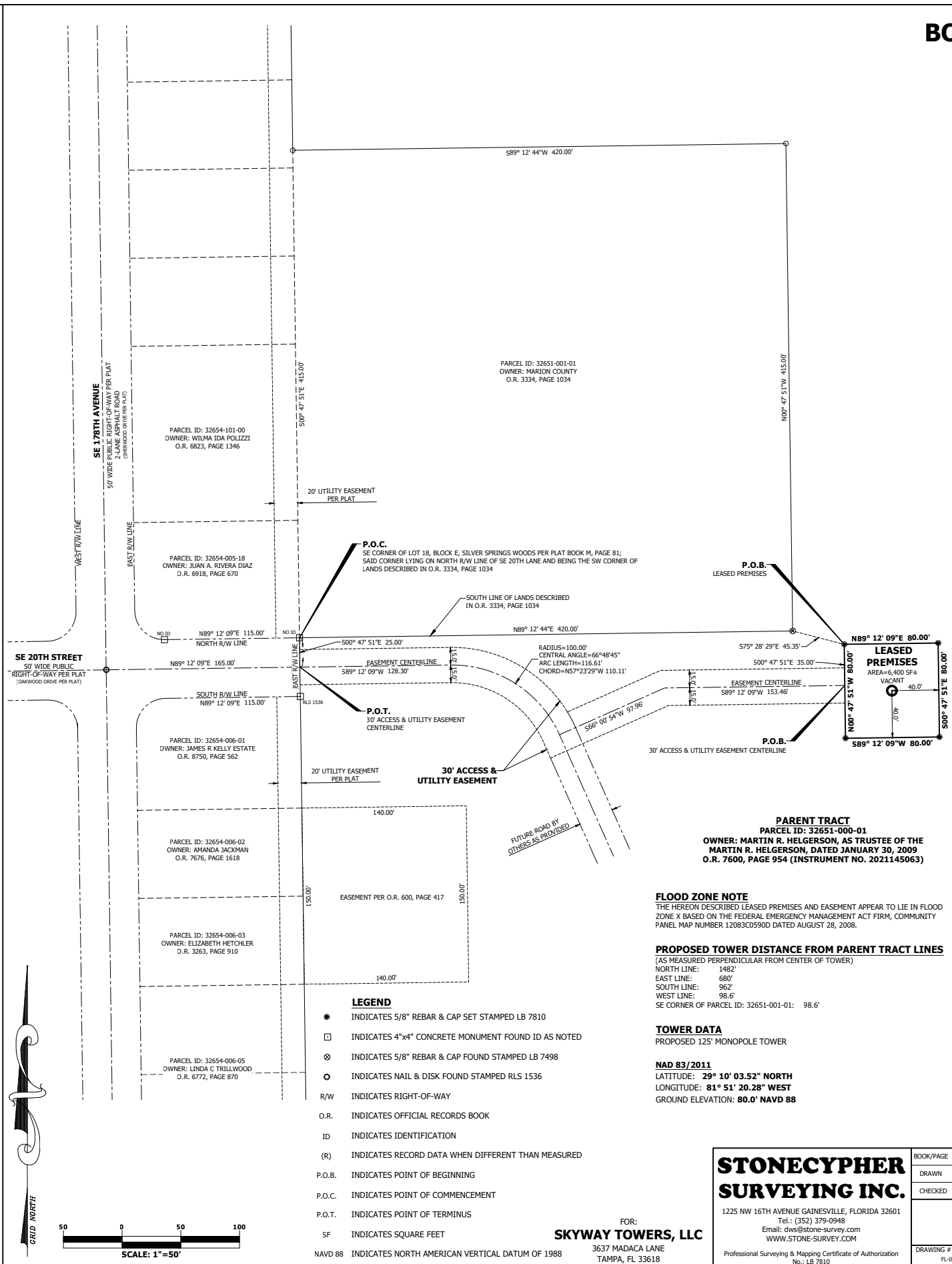
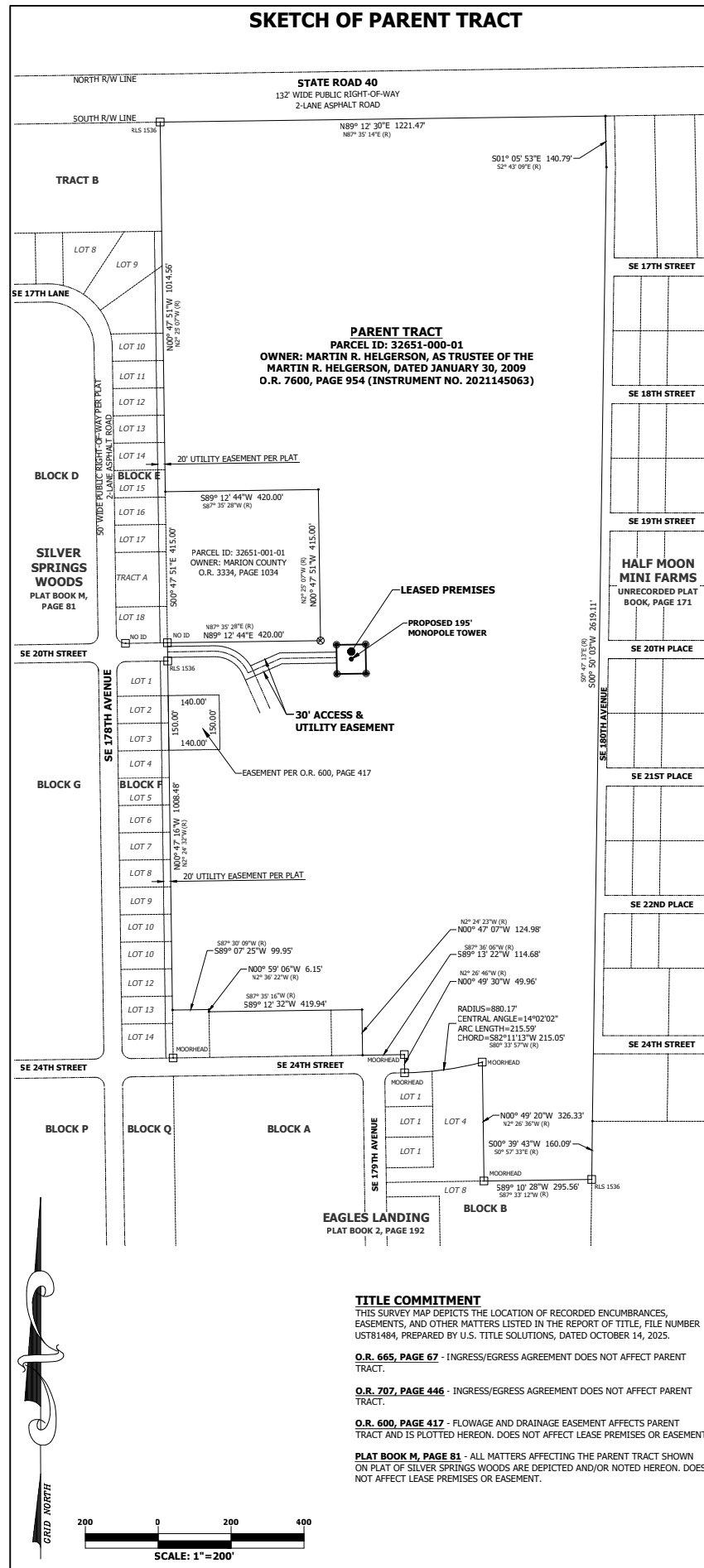

BOUNDARY & TOPOGRAPHIC SURVEY OF SKYWAY TOWERS LEASED PREMISES
 IN SECTION 24, TOWNSHIP 15 SOUTH, RANGE 24 EAST, MARION COUNTY, FLORIDA

PARENT TRACT DESCRIPTION (PER TITLE REPORT & O.R. 7600, PAGE 954)
 COMMENCE AT THE NE CORNER OF TRACT "B", SILVER SPRINGS WOODS AS FOUND IN PLAT BOOK "M" AT PAGE 81, PUBLIC RECORDS OF MARION COUNTY, FLORIDA, SAID POINT BEING ON THE SOUTH RIGHT-OF-WAY LINE OF STATE ROAD 40 (132 FOOT WIDE) AND ALSO THE POINT OF BEGINNING; THENCE N.87°35'14"E. AND ALONG SAID SOUTH RIGHT-OF-WAY LINE A DISTANCE OF 1221.47 FEET TO THE INTERSECTION OF THE EAST BOUNDARY LINE OF THE 1/4 OF SECTION 24, TOWNSHIP 15 SOUTH, RANGE 24 EAST AND THE SOUTH RIGHT-OF-WAY LINE OF STATE ROAD 40; THENCE S.02°43'09"E. AND ALONG SAID EAST LINE OF THE NE 1/4 OF SECTION 24 A DISTANCE OF 140.79 FEET TO THE EAST 1/4 CORNER OF SAID SECTION 24; THENCE S.00°47'13"E. AND ALONG THE EAST LINE OF THE SE 1/4 OF SAID SECTION 24 A DISTANCE OF 2619.11 FEET TO THE SE CORNER OF SAID SECTION 24, ALSO BEING THE NE CORNER OF SECTION 25, TOWNSHIP 15 SOUTH, RANGE 24 EAST, THENCE S.00°57'33"E. AND ALONG THE EAST LINE OF THE NE 1/4 OF SAID SECTION 25 A DISTANCE OF 160.09 FEET; THENCE S.87°33'12"W. A DISTANCE OF 295.56 FEET; THENCE N.02°26'36"W. A DISTANCE OF 326.33 FEET TO A POINT ON A CURVE CONCAVING NORTHERLY HAVING A 880.17 FOOT RADIUS, CHORD OF 215.05 FEET AND CHORD BEARING OF S.80°33'57"W. ; THENCE ALONG THE ARC OF SAID CURVE A DISTANCE OF 215.59 FEET; THENCE N.02°26'46"W. A DISTANCE OF 49.96 FEET; THENCE S.87°36'58"E. A DISTANCE OF 114.68 FEET; THENCE N.02°24'23"W. A DISTANCE OF 128.30 FEET; THENCE S.87°35'16"W. A DISTANCE OF 419.94 FEET; THENCE N.02°36'22"W. A DISTANCE OF 6.15 FEET; THENCE S.87°30'09"W. A DISTANCE OF 99.95 FEET TO A POINT ON THE EAST LINE OF BLOCK F OF THE AFOREMENTIONED SILVER SPRINGS WOODS SUBDIVISION, SAID POINT ALSO BEING 131.00 FEET NORTH OF THE SE CORNER OF LOT 14 OF SAID BLOCK F; THENCE N.02°24'32"W. AND ALONG THE EAST LINE OF SILVER SPRINGS WOODS SUBDIVISION A DISTANCE OF 1008.48 FEET TO A POINT ON THE NORTH RIGHT-OF-WAY LINE OF SE 20TH LANE, SAID POINT ALSO BEING THE SE CORNER OF LOT 18, BLOCK E OF THE AFOREMENTIONED SUBDIVISION; THENCE N.87°35'28"E. A DISTANCE OF 420.00 FEET; THENCE N.02°25'07"W. A DISTANCE OF 415.00 FEET; THENCE S.87°35'28"W. A DISTANCE OF 420.00 FEET TO A POINT ON THE EAST LINE OF SAID BLOCK E AND TRACT "B" A DISTANCE OF 1014.56 FEET TO THE POINT OF BEGINNING. SAID PARCEL LYING AND BEING SITUATED IN THE NE AND SE 1/4'S OF SECTION 24 AND THE NE 1/4 OF SECTION 25, BOTH IN TOWNSHIP 15 SOUTH, RANGE 24 EAST, MARION COUNTY, FLORIDA.

LEASED PREMISES
 A PARCEL OF LAND LYING IN SECTION 24, TOWNSHIP 15 SOUTH, RANGE 24 EAST, MARION COUNTY, FLORIDA; SAID PARCEL OF LAND BEING MORE PARTICULARLY DESCRIBED AS FOLLOWS:
 COMMENCE AT THE SOUTHEAST CORNER OF LOT 18, BLOCK E, SILVER SPRINGS WOODS, ACCORDING TO THE PLAT THEREOF, AS RECORDED IN PLAT BOOK M, PAGE 81 OF THE PUBLIC RECORDS OF MARION COUNTY, FLORIDA, SAID CORNER ALSO LYING ON THE NORTH RIGHT-OF-WAY LINE OF SE 20TH STREET (A 50' PUBLIC RIGHT-OF-WAY); THENCE N89°12'44"E ALONG THE SOUTH LINE OF THOSE LANDS DESCRIBED IN OFFICIAL RECORDS BOOK 3334, PAGE 1034 OF SAID PUBLIC RECORDS FOR 420.00 FEET; THENCE S75°28'29"E FOR 45.35 FEET TO THE POINT OF BEGINNING OF THE HEREIN DESCRIBED PARCEL OF LAND; THENCE N89°12'09"E FOR 80.00 FEET; THENCE S00°47'51"E FOR 80.00 FEET; THENCE S89°12'09"W FOR 80.00 FEET; THENCE N00°47'51"W FOR 80.00 FEET TO THE POINT OF BEGINNING. SAID PARCEL OF LAND SITUATE, LYING AND BEING IN MARION COUNTY, FLORIDA, CONTAINING 6,400 SQUARE FEET MORE OR LESS.

30' ACCESS AND UTILITY EASEMENT
 A 30-FOOT WIDE EASEMENT STRIP OF LAND FOR THE PURPOSE OF ACCESS AND UTILITIES LYING IN SECTION 24, TOWNSHIP 15 SOUTH, RANGE 24 EAST, MARION COUNTY, FLORIDA; SAID EASEMENT STRIP OF LAND LYING 15.00 FEET ON BOTH SIDES OF THE FOLLOWING DESCRIBED EASEMENT CENTERLINE:
 COMMENCE AT THE SOUTHEAST CORNER OF LOT 18, BLOCK E, SILVER SPRINGS WOODS, ACCORDING TO THE PLAT THEREOF, AS RECORDED IN PLAT BOOK M, PAGE 81 OF THE PUBLIC RECORDS OF MARION COUNTY, FLORIDA, SAID CORNER ALSO LYING ON THE NORTH RIGHT-OF-WAY LINE OF SE 20TH STREET (A 50' PUBLIC RIGHT-OF-WAY); THENCE N89°12'44"E ALONG THE SOUTH LINE OF THOSE LANDS DESCRIBED IN OFFICIAL RECORDS BOOK 3334, PAGE 1034 OF SAID PUBLIC RECORDS FOR 420.00 FEET; THENCE S75°28'29"E FOR 45.35 FEET TO A NON-TANGENT POINT ON A CURVE; THENCE NORTHWESTERLY FOR 116.61 FEET ALONG THE ARC OF A CURVE, CONCAVE TO THE SOUTHWEST, HAVING A RADIUS OF 100.00 FEET, CENTRAL ANGLE OF 66°48'45"; SUBTENDED BY A CHORD HAVING A LENGTH OF 110.11 FEET AND BEARING N57°23'29"W, TO A POINT OF TANGENCY; THENCE S89°12'09"W FOR 128.30 FEET TO AN INTERSECTION WITH THE EAST RIGHT-OF-WAY LINE OF THE AFORESAID SE 20TH STREET AND THE POINT OF TERMINUS. THE SIDELINES OF SAID EASEMENT TO BE SHORTENED AND PROLONGED TO MEET AT ANGLE POINTS, LEASED PREMISES LINES AND RIGHT-OF-WAY LINES.

SURVEYOR'S NOTES
 1. BEARINGS SHOWN HEREON ARE GRID NAD83 FLORIDA STATE PLANE, WEST ZONE, ESTABLISHED WITH RTK GPS OBSERVATIONS REFERENCED TO STATE OF FLORIDA PERMANENT REFERENCE NETWORK.
 2. THE BOUNDARY & TOPOGRAPHIC SURVEY SHOWN HEREON IS BASED ON ACTUAL FIELD MEASUREMENTS AND OBSERVATIONS DATED OCTOBER 28, 2025.
 3. THIS SURVEY MAP OR THE COPIES THEREOF ARE NOT VALID WITHOUT THE SIGNATURE AND THE ORIGINAL RAISED SEAL OF A FLORIDA LICENSED SURVEYOR AND MAPPER.
 4. CENTER OF PROPOSED TOWER LATITUDE AND LONGITUDE SHOWN HEREON WERE ESTABLISHED FROM RTK GPS OBSERVATIONS REFERENCED TO THE STATE OF FLORIDA PERMANENT REFERENCE NETWORK. THE VALUES FOR THE PROPOSED TOWER LATITUDE, LONGITUDE AND ELEVATION SHOWN HEREON EXCEED FAA "1-A" ACCURACY REQUIREMENTS. ELEVATIONS SHOWN HEREON ARE NAVD 88 AND REFERENCED TO THE FLORIDA DEPARTMENT OF TRANSPORTATION PERMANENT REFERENCE NETWORK (FPRN).
 5. THE PURPOSE OF THIS SURVEY IS TO SHOW IMPROVEMENTS ASSOCIATED WITH A PROPOSED TELECOMMUNICATIONS FACILITY AND PROVIDE LEGAL DESCRIPTIONS FOR SAID FACILITY AND ASSOCIATED EASEMENT. THIS IS NOT A SURVEY OF THE PARENT TRACT. PARENT TRACT DATA IS FOR INFORMATION ONLY.
 6. MEASURED BEARINGS AND DISTANCES WERE IN SUBSTANTIAL AGREEMENT WITH RECORD DATA UNLESS OTHERWISE NOTED.
 7. PROPERTY TIES ARE PERPENDICULAR MEASURE UNLESS OTHERWISE NOTED.
 8. UNDERGROUND FOUNDATIONS AND UTILITIES WERE NOT LOCATED AS PART OF THIS SURVEY UNLESS OTHERWISE NOTED HEREON.
 9. THE LEASED PREMISES AND THE 30' ACCESS & UTILITY EASEMENT ARE LOCATED ENTIRELY WITHIN THE DESCRIBED PARENT TRACT.
 10. THIS SURVEY CONSISTS OF 2 SHEETS. SEE SHEET 2 FOR IMPROVEMENTS, TOPOGRAPHIC DATA AND ADDITIONAL INFORMATION.

STONECYPHER SURVEYING INC.
 1225 NW 16TH AVENUE GAINESVILLE, FLORIDA 32601
 Tel.: (352) 379-0948
 Email: dws@stone-survey.com
 WWW.STONE-SURVEY.COM
 Professional Surveying & Mapping Certificate of Authorization
 No.: LB 7810

COMMUNICATION TOWER SITE -- SILVER SPRINGS NUMBER: SKYWAY FL-01106

BOOK/PAGE	54/28	This map prepared by:	DAVID W. STONECYPHER	SCALE	AS SHOWN
DRAWN	DWS	DATE	11-20-2025	DATE	OCTOBER 28, 2025
CHECKED	DWS	PROFESSIONAL SURVEYOR & MAPPER FLA. LICENSE NO. 6391		PROJECT #	25-0064
DRAWING #			FL-01106.SURVEY.DWG	SHEET #	
				1 OF 2	

**BOUNDARY & TOPOGRAPHIC SURVEY
OF SKYWAY TOWERS LEASED PREMISES**

IN SECTION 24, TOWNSHIP 15 SOUTH, RANGE 24 EAST,
MARION COUNTY, FLORIDA

PARENT TRACT
PARCEL ID: 32651-000-01
OWNER: MARTIN R. HELGERSON, AS TRUSTEE OF THE
MARTIN R. HELGERSON, DATED JANUARY 30, 2009
O.R. 7600, PAGE 954 (INSTRUMENT NO. 2021145063)

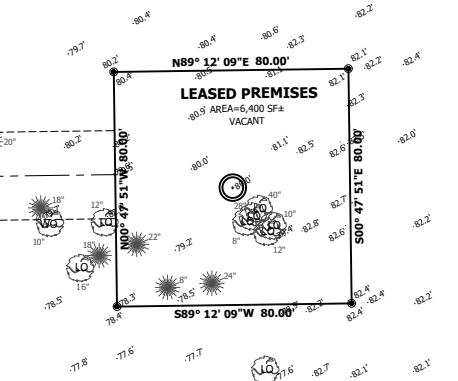
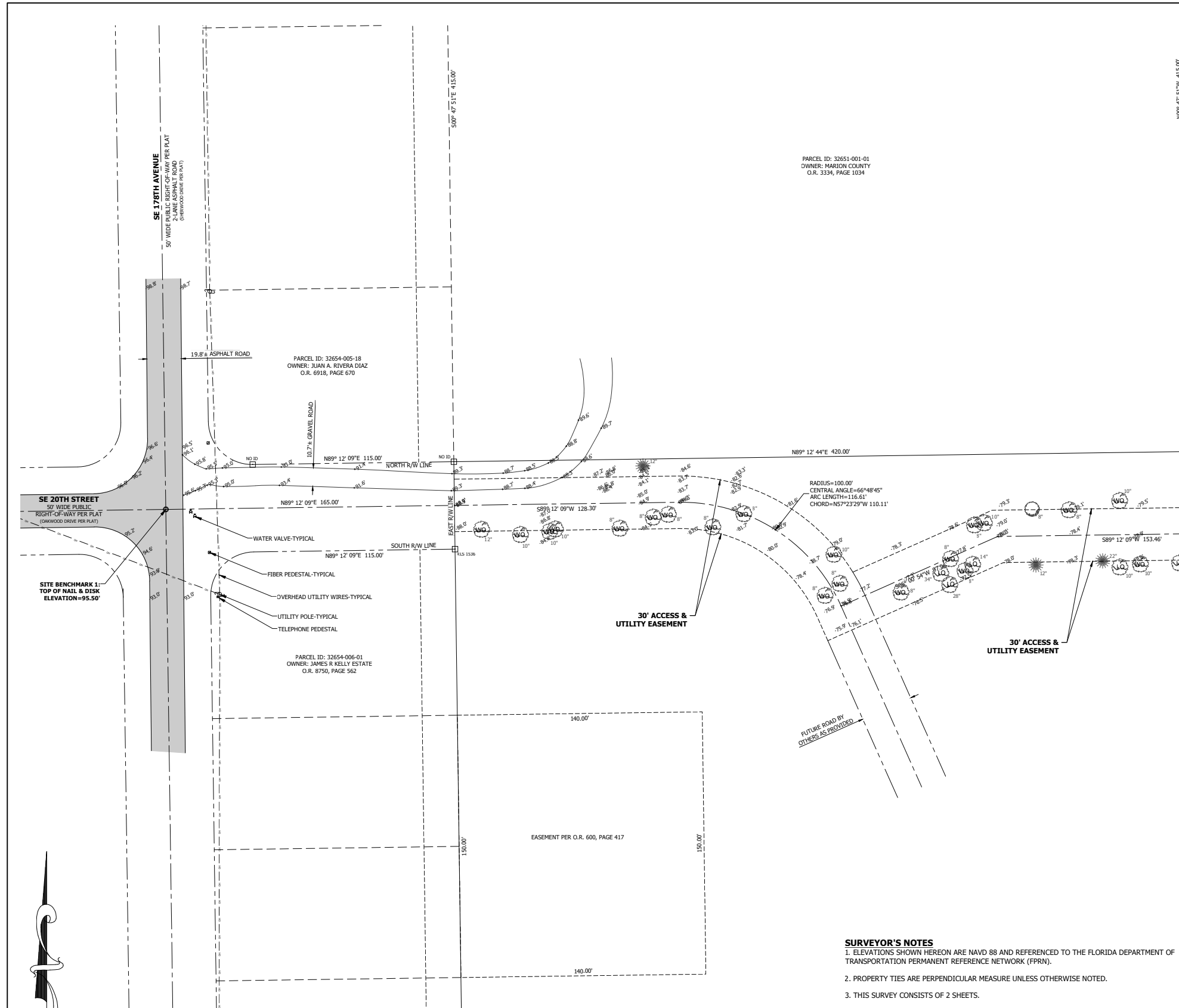

LEGEND

- INDICATES 5/8" REBAR & CAP SET STAMPED LB 7810
- INDICATES 4"x4" CONCRETE MONUMENT FOUND ID AS NOTED
- ⊗ INDICATES 5/8" REBAR & CAP FOUND STAMPED LB 7498
- INDICATES NAIL & DISK FOUND STAMPED RLS 1536
- R/W INDICATES RIGHT-OF-WAY
- O.R. INDICATES OFFICIAL RECORDS BOOK
- ID INDICATES IDENTIFICATION
- (R) INDICATES RECORD DATA WHEN DIFFERENT THAN MEASURED
- P.O.B. INDICATES POINT OF BEGINNING
- P.O.C. INDICATES POINT OF COMMENCEMENT
- P.O.T. INDICATES POINT OF TERMINUS
- SF INDICATES SQUARE FEET
- NAVD 88 INDICATES NORTH AMERICAN VERTICAL DATUM OF 1988
- INDICATES EXISTING SPOT ELEVATION

TREE LEGEND

- CHERRY TREE
- LIVE OAK TREE
- WATER OAK TREE
- ☀ PINE TREE
- 14" INDICATES TREE DIAMETER
- 18"+18"+18" INDICATES TREE DIAMETERS OF TREE CLUSTER
- ALL TREES 8"+ WITHIN THE LEASED PREMISES AND EASEMENTS WERE LOCATED AND ARE DEPICTED HEREON

SURVEYOR'S NOTES
1. ELEVATIONS SHOWN HEREON ARE NAVD 88 AND REFERENCED TO THE FLORIDA DEPARTMENT OF TRANSPORTATION PERMANENT REFERENCE NETWORK (FPRN).
2. PROPERTY TIES ARE PERPENDICULAR MEASURE UNLESS OTHERWISE NOTED.
3. THIS SURVEY CONSISTS OF 2 SHEETS.



STONECYPHER SURVEYING INC.
1225 NW 16TH AVENUE GAINESVILLE, FLORIDA 32601
Tel.: (352) 379-0948
Email: dws@stone-surveying.com
WWW.STONE-SURVEY.COM
Professional Surveying & Mapping Certificate of Authorization No.: LB 7810

BOOK/PAGE	54/28	SCALE	1" = 30'
DRAWN	DWS	DATE	OCTOBER 28, 2025
CHECKED	DWS	PROJECT #	25-0064
COMMUNICATION TOWER SITE -- SILVER SPRINGS NUMBER: SKYWAY FL-01106			
DRAWING #	FL-01106.SURVEY.DWG	SHEET #	2 OF 2

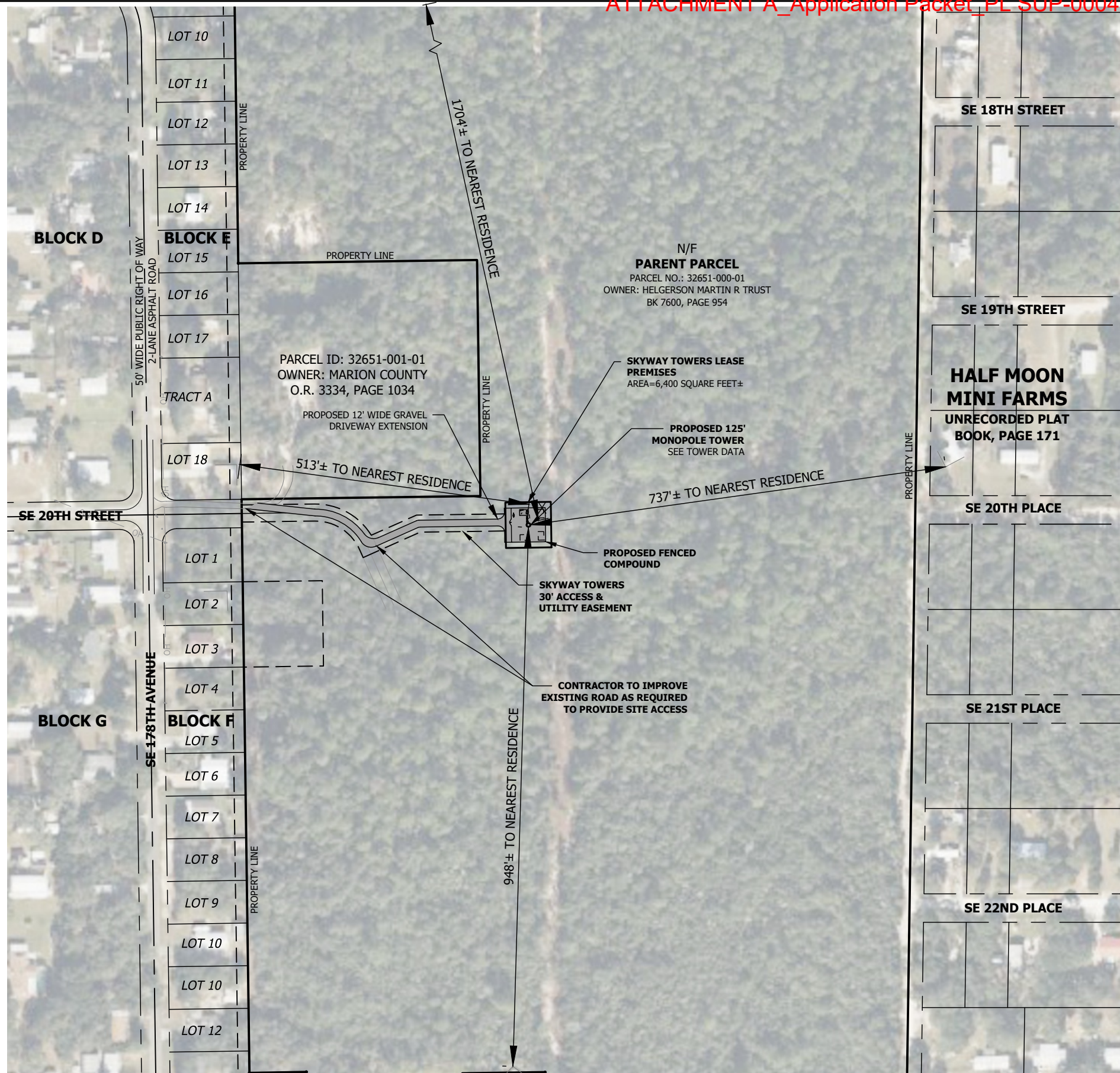

NOTES:

1. TOWER LATITUDE, LONGITUDE & ELEVATION MEET FAA"1-A" ACCURACY REQUIREMENTS.
2. EXISTING FEATURES SHOWN HEREON ARE BASED ON ACTUAL FIELD MEASUREMENTS AND OBSERVATIONS PERFORMED BY STONECYPHER SURVEYING INC., DATED OCTOBER 28, 2025.
3. THE CONTRACTOR SHALL FIELD-VERIFY THE LOCATION OF ALL EXISTING ABOVE GROUND AND UNDERGROUND IMPROVEMENTS PRIOR TO COMMENCEMENT OF CONSTRUCTION.
4. THE CONTRACTOR SHALL BE RESPONSIBLE FOR ANY NECESSARY RELOCATION OR REPAIR OF EXISTING IMPROVEMENTS DUE TO DAMAGE CAUSED DURING CONSTRUCTION.
5. ALL SITE WORK SHALL BE CAREFULLY COORDINATED BY THE CONTRACTOR WITH LOCAL GAS, ELECTRIC, TELEPHONE AND ANY OTHER UTILITY COMPANIES HAVING JURISDICTION OVER THIS PROJECT.
6. CONTRACTOR TO VERIFY POWER & TELCO DEMARCS WITH UTILITY PROVIDERS PRIOR TO BIDDING PROJECT.
7. TOWER SITE IS NOT WITHIN AN AIRPORT OVERLAY.
8. THE NEAREST CELL TOWER, 366' GUYED TOWER OWNED BY COMMUNITY COMMUNICATIONS, INC. IS 11,200'± TO THE NORTHWEST OF THE PROPOSED TOWER.
9. THE NEAREST RESIDENCE IS 513'± WEST OF THE PROPOSED TOWER (EXCEEDS 1:1 +50' TOWER HEIGHT).
10. THE NEAREST WETLAND IS 1,826'± SOUTH OF THE PROPOSED TOWER.
11. THE NEAREST RIGHT OF WAY OF AN ARTERIAL OR MAJOR COLLECTOR (HWY 40) IS 1,480'± FROM THE PROPOSED TOWER (EXCEEDS 500').

NEAREST RESIDENTIAL STRUCTURES:

- NORTH: 1704'±
- EAST: 737'±
- SOUTH: 948'±
- WEST: 513'±
- TOWER HEIGHT = 125'

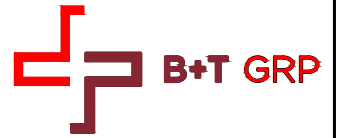

SKYWAY TOWERS
SILVER SPRINGS
 PARCEL ID: 32651-000-01
 SE 24TH STREET
 SILVER SPRINGS, FL 32179
 MARION COUNTY
 PROPOSED 125' MONOPOLE TOWER

PROJECT NO:	25-000937		
CHECKED BY:	MAS		
ISSUED FOR:			
REV	DATE	DRWN	DESCRIPTION
A	12/29/25	DRT	PRELIMINARY

B&T ENGINEERING, INC.
 1717 S. BOULDER AVENUE
 TULSA, OK 74119

THIS DOCUMENT IS PRELIMINARY IN NATURE AND IS NOT A FINAL, SIGNED AND SEALED DOCUMENT

IT IS A VIOLATION OF LAW FOR ANY PERSON, UNLESS THEY ARE ACTING UNDER THE DIRECTION OF A LICENSED PROFESSIONAL ENGINEER, TO ALTER THIS DOCUMENT.

AERIAL SHEET

SHEET NUMBER:
C-1

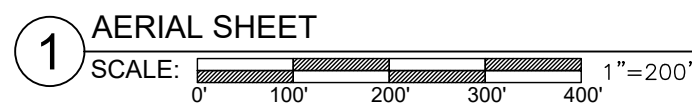

CALL FLORIDA ONE CALL
 (800) 432-4770
 CALL 3 WORKING DAYS
 BEFORE YOU DIG!



FLOOD ZONE NOTE
 THE HEREON DESCRIBED LEASE PARCEL AND EASEMENTS APPEARS TO LIE IN FLOOD ZONE X BASED ON THE FEDERAL EMERGENCY MANAGEMENT ACT FIRM, COMMUNITY PANEL MAP NUMBER 12083C0590D DATED AUGUST 28, 2008.

TOWER DATA	
PROPOSED 125' MONOPOLE	
NAD 83	
LATITUDE:	29° 10' 03.52" N (29.167644°) N
LONGITUDE:	-81° 51' 20.28" W (-81.855633°) W
GROUND ELEVATION:	80.0' NAVD 1988 (AVERAGE)

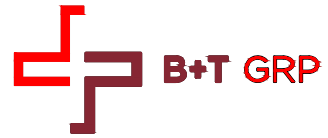

SKYWAY TOWERS
SILVER SPRINGS
 PARCEL ID: 32651-000-01
 SE 24TH STREET
 SILVER SPRINGS, FL 32179
 MARION COUNTY
 PROPOSED 125' MONOPOLE TOWER

PROJECT NO:	25-000937		
CHECKED BY:	MAS		
ISSUED FOR:			
REV	DATE	DRWN	DESCRIPTION
A	12/29/25	DRT	PRELIMINARY

B&T ENGINEERING, INC.
 1717 S. BOULDER AVENUE
 TULSA, OK 74119

THIS DOCUMENT IS PRELIMINARY IN NATURE AND IS NOT A FINAL, SIGNED AND SEALED DOCUMENT

IT IS A VIOLATION OF LAW FOR ANY PERSON, UNLESS THEY ARE ACTING UNDER THE DIRECTION OF A LICENSED PROFESSIONAL ENGINEER, TO ALTER THIS DOCUMENT.

OVERALL SITE PLAN

SHEET NUMBER:
C-2

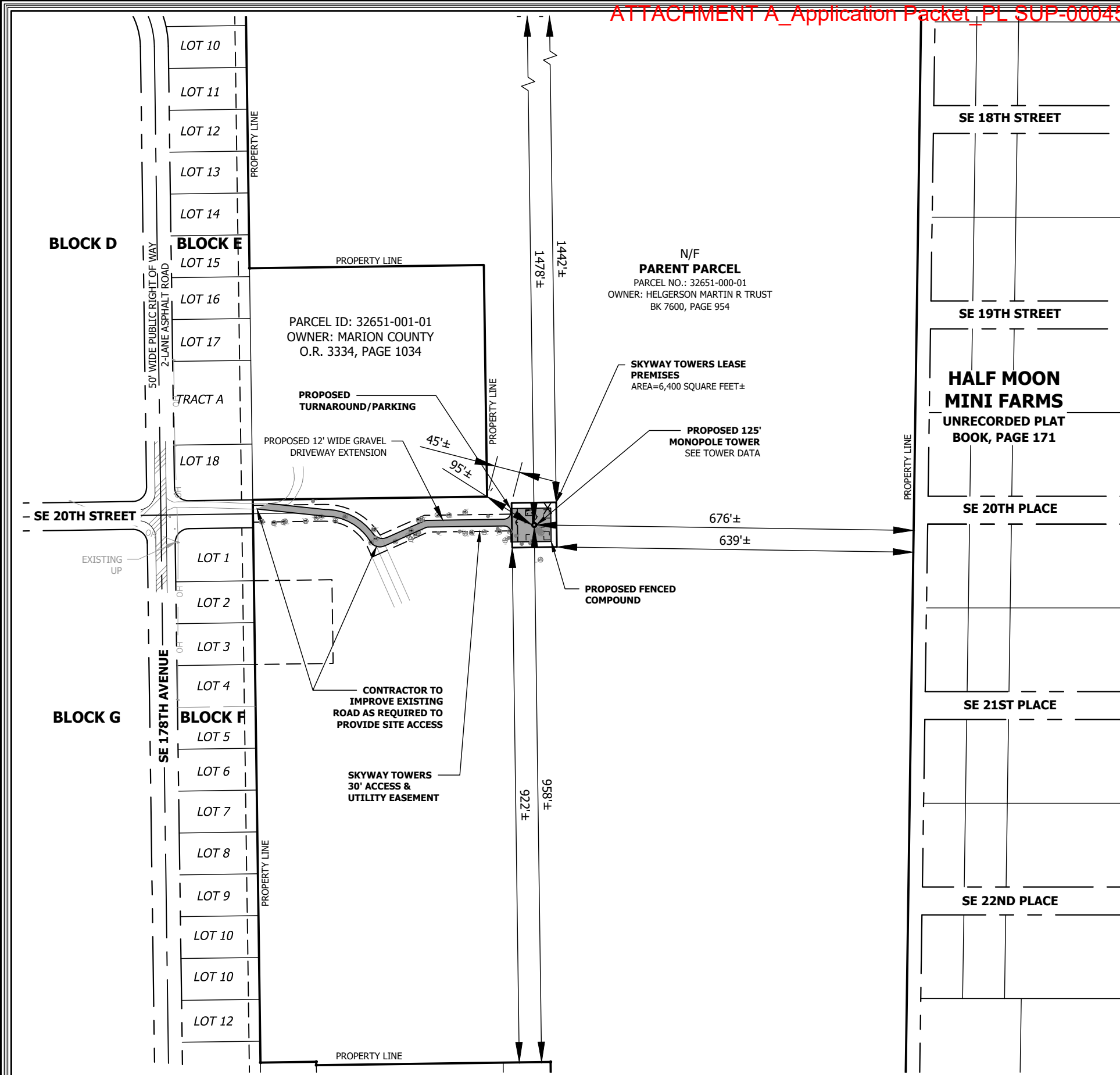

1 OVERALL SITE PLAN
 SCALE: 1" = 200'
 0' 100' 200' 300' 400'



CALL FLORIDA ONE CALL
 (800) 432-4770
 CALL 3 WORKING DAYS
 BEFORE YOU DIG!



Silver Springs FL-01106_ZDs (A).dwg - Sheet:C-2 - User: daniel.tamayo - Dec 29, 2025 - 9:00am

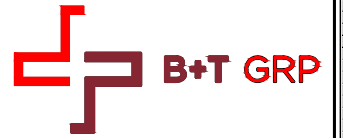

SKYWAY
TOWERS
SILVER SPRINGS
PARCEL ID: 32651-000-01
SE 24TH STREET
SILVER SPRINGS, FL 32179
MARION COUNTY
PROPOSED 125' MONOPOLE
TOWER

PROJECT NO: 25-000937
CHECKED BY: MAS

ISSUED FOR:

REV	DATE	DRWN	DESCRIPTION
A	12/29/25	DRT	PRELIMINARY

B&T ENGINEERING, INC.
1717 S. BOULDER AVENUE
TULSA, OK 74119

**THIS DOCUMENT IS
PRELIMINARY IN
NATURE AND IS NOT
A FINAL, SIGNED
AND SEALED
DOCUMENT**

IT IS A VIOLATION OF LAW FOR ANY PERSON, UNLESS
THEY ARE ACTING UNDER THE DIRECTION OF A LICENSED
PROFESSIONAL ENGINEER, TO ALTER THIS DOCUMENT.

ENLARGED
COMPOUND
LAYOUT

SHEET NUMBER:
C-3

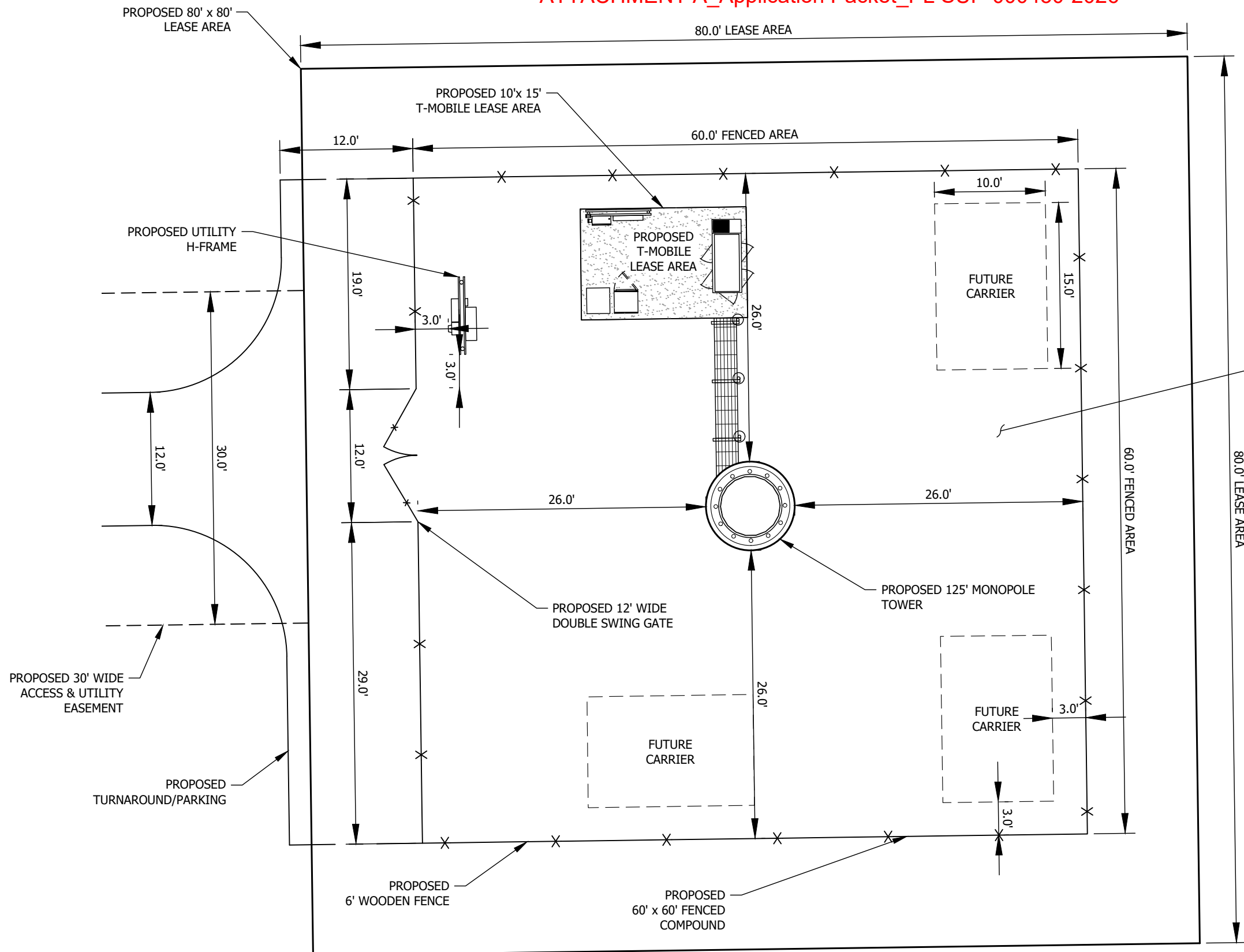

1 COMPOUND LAYOUT
SCALE: 1" = 10'



CALL FLORIDA ONE CALL
(800) 432-4770
CALL 3 WORKING DAYS
BEFORE YOU DIG!



Silver Springs FL-01106_ZDs (A).dwg - Sheet:C-3 - User: daniel.tamayo - Dec 29, 2025 - 9:00am

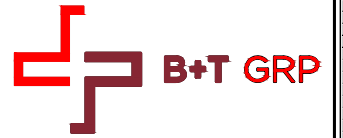

SKYWAY
TOWERS
SILVER SPRINGS
PARCEL ID: 32651-000-01
SE 24TH STREET
SILVER SPRINGS, FL 32179

MARION COUNTY
PROPOSED 125' MONOPOLE
TOWER

PROJECT NO: 25-000937
CHECKED BY: MAS

ISSUED FOR:

REV	DATE	DRWN	DESCRIPTION
A	12/29/25	DRT	PRELIMINARY

B&T ENGINEERING, INC.
1717 S. BOULDER AVENUE
TULSA, OK 74119

**THIS DOCUMENT IS
PRELIMINARY IN
NATURE AND IS NOT
A FINAL, SIGNED
AND SEALED
DOCUMENT**

IT IS A VIOLATION OF LAW FOR ANY PERSON, UNLESS
THEY ARE ACTING UNDER THE DIRECTION OF A LICENSED
PROFESSIONAL ENGINEER, TO ALTER THIS DOCUMENT.

TOWER
ELEVATION

SHEET NUMBER:
C-4

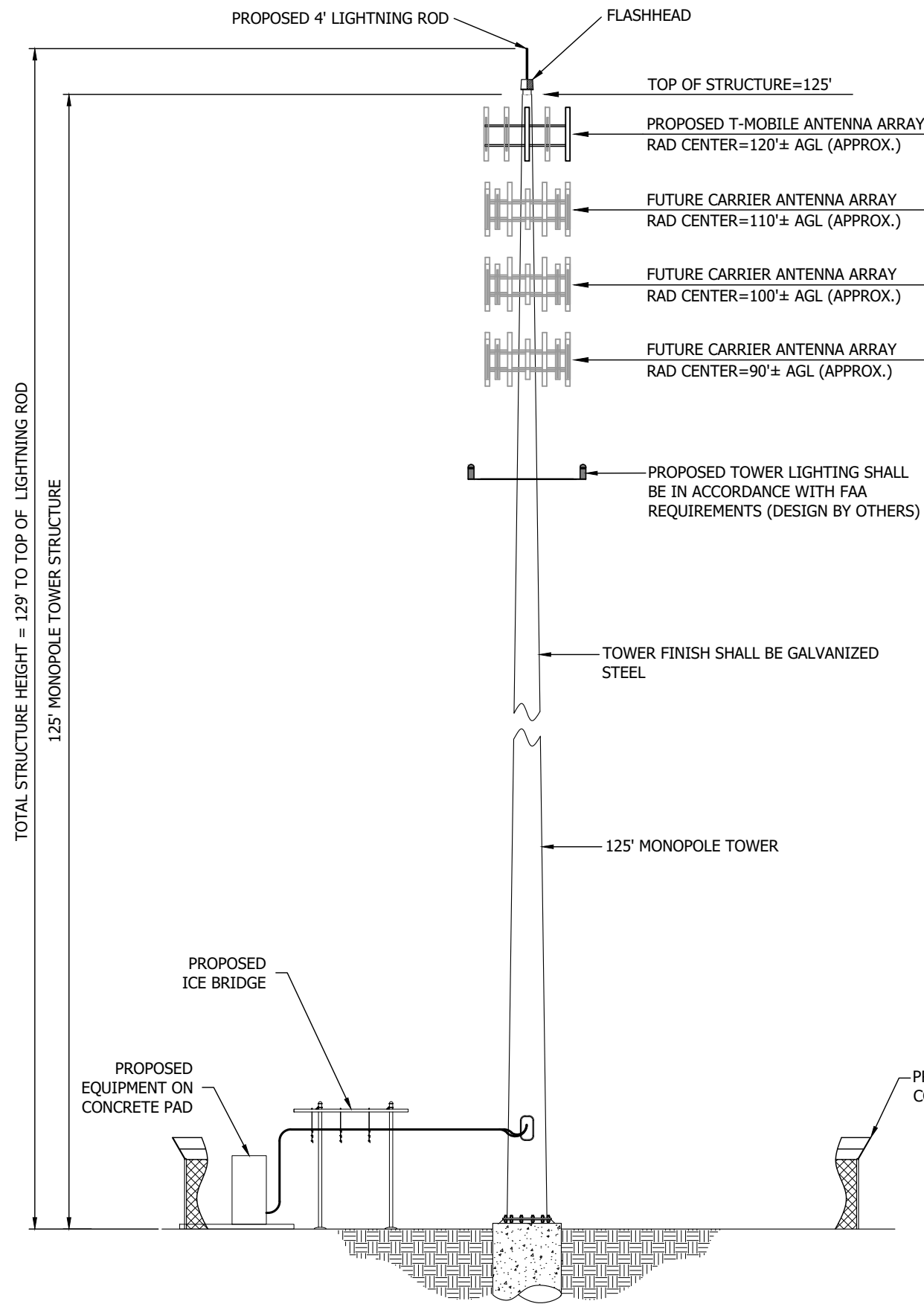

1 TOWER ELEVATION
SCALE: N.T.S.

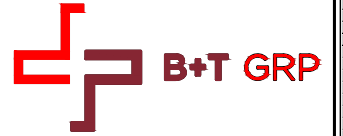

SKYWAY
TOWERS
SILVER SPRINGS
PARCEL ID: 32651-000-01
SE 24TH STREET
SILVER SPRINGS, FL 32179

MARION COUNTY
PROPOSED 125' MONOPOLE
TOWER

PROJECT NO: 25-000937
CHECKED BY: MAS
ISSUED FOR:

REV	DATE	DRWN	DESCRIPTION
A	12/29/25	DRT	PRELIMINARY

B&T ENGINEERING, INC.
1717 S. BOULDER AVENUE
TULSA, OK 74119

**THIS DOCUMENT IS
PRELIMINARY IN
NATURE AND IS NOT
A FINAL, SIGNED
AND SEALED
DOCUMENT**

IT IS A VIOLATION OF LAW FOR ANY PERSON, UNLESS
THEY ARE ACTING UNDER THE DIRECTION OF A LICENSED
PROFESSIONAL ENGINEER, TO ALTER THIS DOCUMENT.

CONSTRUCTION
DETAILS

SHEET NUMBER:
C-5

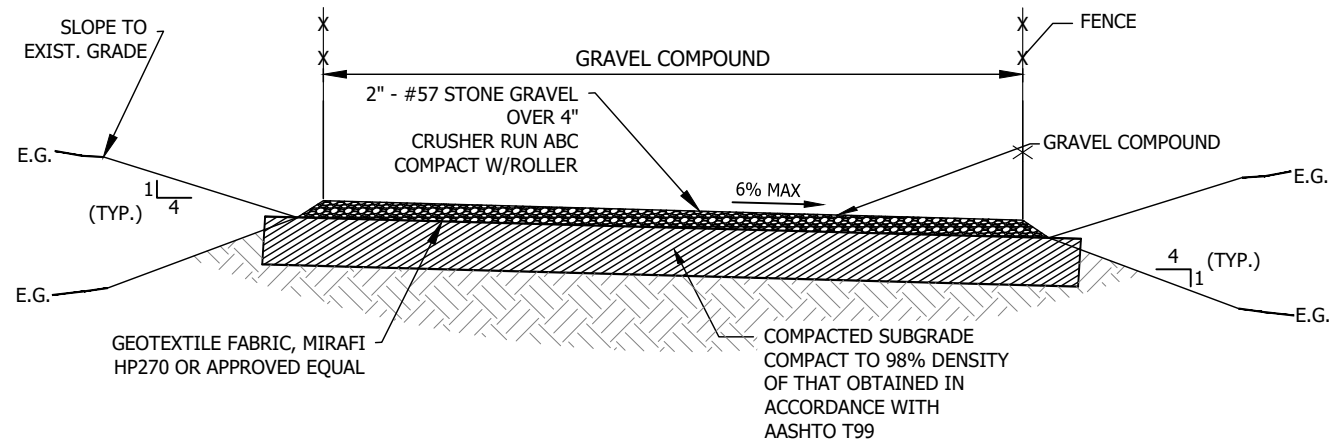

1 ON GRADE GRAVEL COMPOUND SECTION
SCALE: N.T.S.

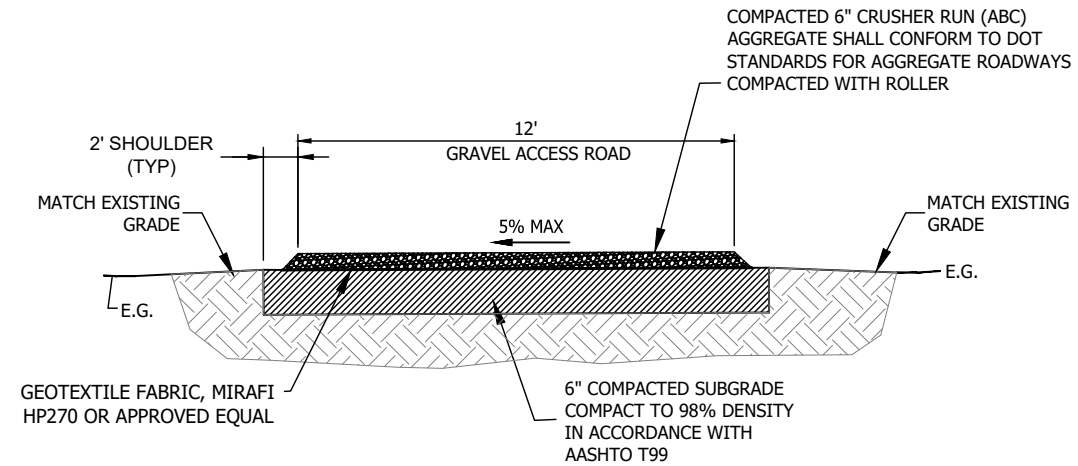

NOTES:

1. THE CONTRACTOR MUST EITHER SUPER-ELEVATE OR CROWN ALL ROAD SECTIONS.
2. THE MAXIMUM SUPER-ELEVATION SHALL NOT EXCEED 5% CROSS SLOPE.

2 ON GRADE GRAVEL ROAD SECTION
SCALE: N.T.S.

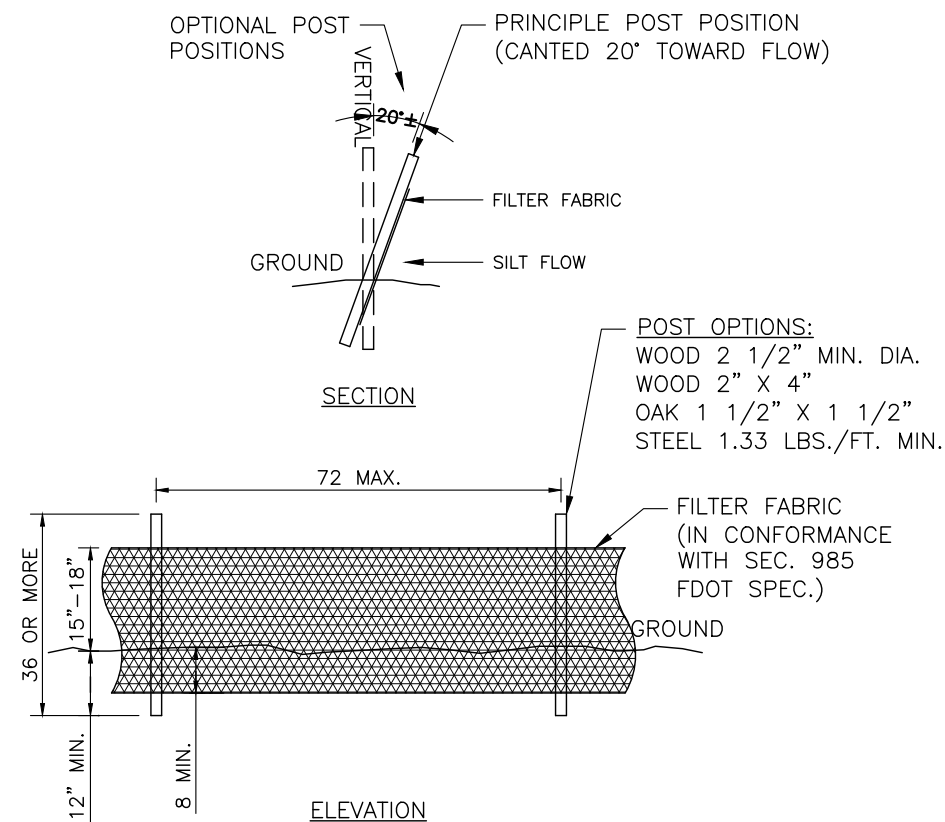

3 F.D.O.T. TYPE E-1 SILT FENCE
SCALE: N.T.S.

NOTES:

- SIGNS SHALL BE FABRICATED FROM CORROSION RESISTANT PRESSED METAL, AND PAINTED WITH LONG LASTING UV RESISTANT COATINGS.
- SIGNS (EXCEPT WHERE NOTED OTHERWISE) SHALL BE MOUNTED TO THE TOWER, GATE AND FENCE USING A MINIMUM OF 9 GAUGE ALUMINUM WIRE, HOG RINGS (AS UTILIZED IN FENCE INSTALLATIONS) OR BRACKETS WHERE NECESSARY. BRACKETS SHALL BE OF SIMILAR METAL AS THE STRUCTURE TO AVOID GALVANIC CORROSION.
- ADDITIONAL E911 ADDRESS SIGNS ARE REQUIRED AT EACH ACCESS ROAD GATE LEADING TO THE COMPOUND AS WELL AS ON THE COMPOUND GATE ITSELF.
- ADDITIONAL FCC REGISTRATION # SIGNS ARE REQUIRED AT EACH ACCESS ROAD GATE LEADING TO THE COMPOUND AS WELL AS ON THE COMPOUND GATE ITSELF. SIGN SHALL MEASURE (20" LONG x 4" TALL). THE LETTERS SHALL BE 1" AND THE NUMBERS SHALL BE 2".
- RECOMMENDED SOURCES FOR OBTAINING SIGNAGE:

ST. CLAIR SIGNS 3184 WADE HAMPTON BOULEVARD TAYLORS, SC 29687 (864) 244-0040	RF EXPOSURE SIGNS RICHARD TELL ASSOCIATES 3433 RINGSTAR ROAD, SUITE 3 NORTH LAS VEGAS, NV 89030 (702) 645-3338
EXCEL SIGN & DECAL 1509 NORTH MILPITAS BLVD. MILPITAS, CA 95035 (408) 942-8881	
- NO ADVERTISING SIGNS INCLUDING COMMERCIAL, ADVERTISING, LOGOS, POLITICAL SIGNS, FLYERS, FLAGS OR BANNERS WHETHER OR NOT POSTED TEMPORARILY, SHALL BE PERMITTED ARE WARNING, DANGER, OR OTHER SIGNS DESIGNED TO MAINTAIN PUBLIC SAFETY.

ATTENTION

THE SITE SHALL ONLY CONTAIN SIGNAGE AS MANDATED BY THE FCC.



④ WHITE BACKGROUND WITH BLACK LETTERING
 QUANTITY: (2)
 TO BE MOUNTED ON: COMPOUND ACCESS GATE
 ACCESS DRIVE GATE
 (SEE NOTE 4)

NOTE:
 NUMBER SHOWN IS GENERIC,
 CONTRACT CONSTRUCTION MANAGER
 FOR ACTUAL FCC TOWER REG. #.



EMERGENCY SIGN
 (RED METAL W/ WHITE LETTERING)



CONTRACTOR SHALL VERIFY ADDRESS PRIOR TO ORDERING SIGNAGE.

RED LETTERS (ALL OTHERS BLACK)
 CONTRACTOR TO COORDINATE NUMBERS (TYP)

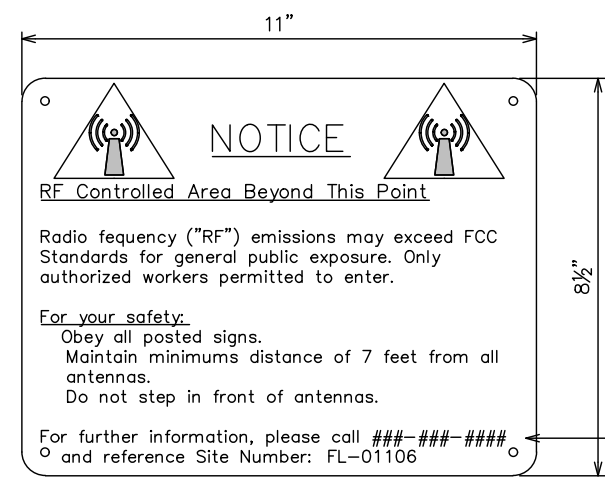

RF NOTICE SIGN
 (WHITE METAL SIGN W/BLACK LETTERING)

CONTRACTOR TO COORDINATE NUMBERS (TYP)

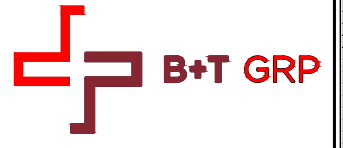

SKYWAY TOWERS
SILVER SPRINGS
 PARCEL ID: 32651-000-01
 SE 24TH STREET
 SILVER SPRINGS, FL 32179
 MARION COUNTY
 PROPOSED 125' MONOPOLE TOWER

PROJECT NO: 25-000937
 CHECKED BY: MAS

ISSUED FOR:

REV	DATE	DRWN	DESCRIPTION
A	12/29/25	DRT	PRELIMINARY

B&T ENGINEERING, INC.
 1717 S. BOULDER AVENUE
 TULSA, OK 74119

THIS DOCUMENT IS PRELIMINARY IN NATURE AND IS NOT A FINAL, SIGNED AND SEALED DOCUMENT

IT IS A VIOLATION OF LAW FOR ANY PERSON, UNLESS THEY ARE ACTING UNDER THE DIRECTION OF A LICENSED PROFESSIONAL ENGINEER, TO ALTER THIS DOCUMENT.

SIGNAGE DETAILS

SHEET NUMBER:
C-6

TYPICAL SIGNS AND SPECIFICATIONS

SCALE: N.T.S.

Silver Springs FL-01106_ZDs (A).dwg - Sheet: C-6 - User: daniel.tamayo - Dec 29, 2025 - 9:00am

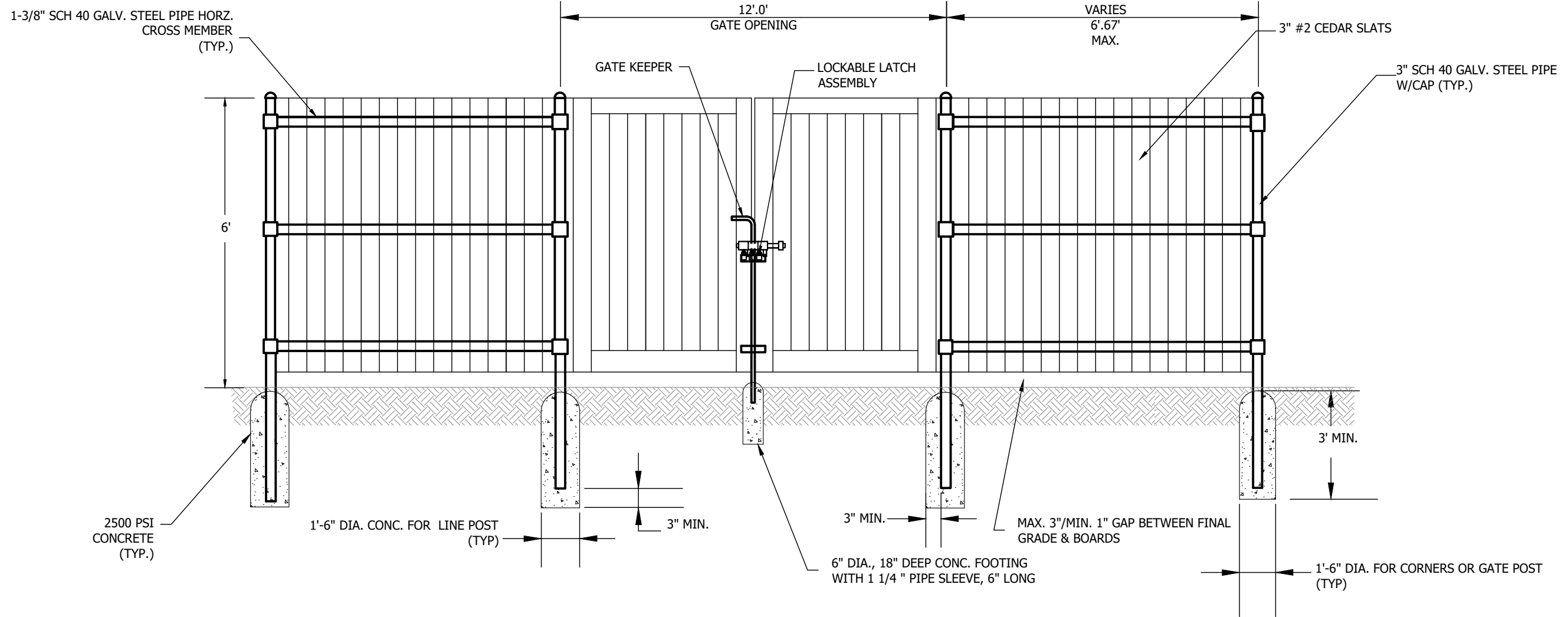

1 TYPICAL 6' WOOD FENCE DETAIL
SCALE: N.T.S.

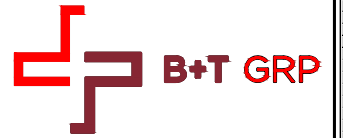

SKYWAY
TOWERS
SILVER SPRINGS
PARCEL ID: 32651-000-01
SE 24TH STREET
SILVER SPRINGS, FL 32179

MARION COUNTY
PROPOSED 125' MONOPOLE
TOWER

PROJECT NO:	25-000937		
CHECKED BY:	MAS		
ISSUED FOR:			
REV	DATE	DRWN	DESCRIPTION
A	12/29/25	DRT	PRELIMINARY

B&T ENGINEERING, INC.
1717 S. BOULDER AVENUE
TULSA, OK 74119

**THIS DOCUMENT IS
PRELIMINARY IN
NATURE AND IS NOT
A FINAL, SIGNED
AND SEALED
DOCUMENT**

IT IS A VIOLATION OF LAW FOR ANY PERSON, UNLESS
THEY ARE ACTING UNDER THE DIRECTION OF A LICENSED
PROFESSIONAL ENGINEER, TO ALTER THIS DOCUMENT.

FENCE DETAILS

SHEET NUMBER:
C-7

Silver Springs FL-01106_ZDs (A).dwg - Sheet: C-7 - User: daniel.tamayo - Dec 29, 2025 - 9:00am

SKETCH OF PARENT TRACT

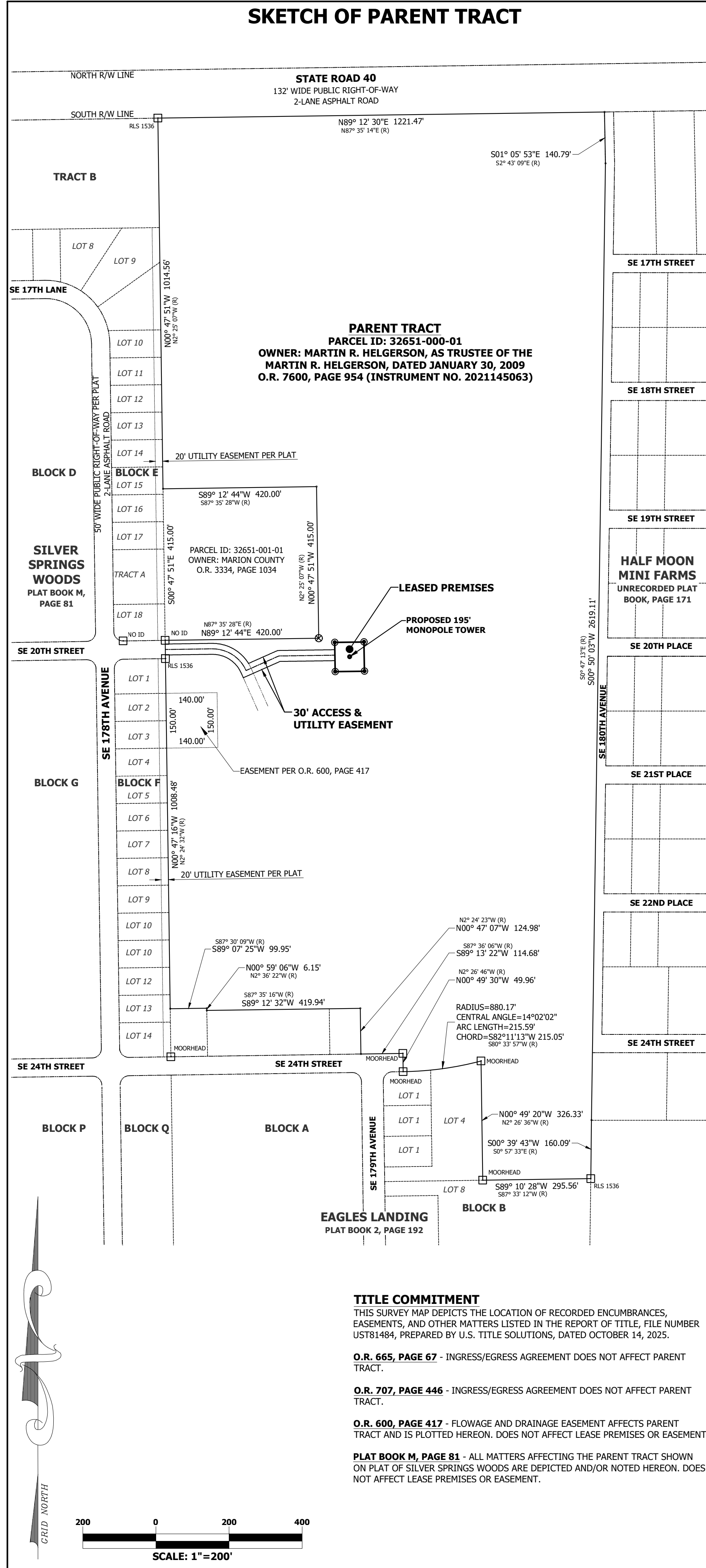

BOUNDARY & TOPOGRAPHIC SURVEY OF SKYWAY TOWERS LEASED PREMISES

IN SECTION 24, TOWNSHIP 15 SOUTH, RANGE 24 EAST, MARION COUNTY, FLORIDA

PARENT TRACT DESCRIPTION (PER TITLE REPORT & O.R. 7600, PAGE 954)
COMMENCE AT THE NE CORNER OF TRACT "B", SILVER SPRINGS WOODS AS FOUND IN PLAT BOOK "M" AT PAGE 81, PUBLIC RECORDS OF MARION COUNTY, FLORIDA, SAID POINT BEING ON THE SOUTH RIGHT-OF-WAY LINE OF STATE ROAD 40 (132 FOOT WIDE) AND ALSO THE POINT OF BEGINNING; THENCE N.87°35'14"E. AND ALONG SAID SOUTH RIGHT-OF-WAY LINE A DISTANCE OF 1221.47 FEET TO THE INTERSECTION OF THE EAST BOUNDARY LINE OF THE NE 1/4 OF SECTION 24, TOWNSHIP 15 SOUTH, RANGE 24 EAST AND THE SOUTH RIGHT-OF-WAY LINE OF STATE ROAD 40; THENCE S.02°43'09"E. AND ALONG SAID EAST LINE OF THE NE 1/4 OF SECTION 24 A DISTANCE OF 140.79 FEET TO THE EAST 1/4 CORNER OF SAID SECTION 24; THENCE S.00°47'13"E. AND ALONG THE EAST LINE OF THE SE 1/4 OF SAID SECTION 24 A DISTANCE OF 2619.11 FEET TO THE SE CORNER OF SAID SECTION 24, ALSO BEING THE NE CORNER OF SECTION 25, TOWNSHIP 15 SOUTH, RANGE 24 EAST, THENCE S.00°57'33"E. AND ALONG THE EAST LINE OF THE NE 1/4 OF SAID SECTION 25 A DISTANCE OF 160.09 FEET; THENCE S.87°33'12"W. A DISTANCE OF 295.56 FEET; THENCE N.02°26'36"W. A DISTANCE OF 336.33 FEET TO A POINT ON A CURVE CONCAVING NORTHERLY HAVING A 880.17 FOOT RADIUS, CHORD OF 215.05 FEET AND CHORD BEARING OF S.80°33'57"W. ; THENCE ALONG THE ARC OF SAID CURVE A DISTANCE OF 215.59 FEET; THENCE N.02°26'46"W. A DISTANCE OF 49.96 FEET; THENCE S.87°36'06"W. A DISTANCE OF 114.68 FEET; THENCE N.02°24'23"W. A DISTANCE OF 124.98 FEET; THENCE S.87°35'16"W. A DISTANCE OF 419.94 FEET; THENCE N.02°36'22"W. A DISTANCE OF 6.15 FEET; THENCE S.87°30'09"W. A DISTANCE OF 99.95 FEET TO A POINT ON THE EAST LINE OF BLOCK F OF THE AFOREMENTIONED SILVER SPRINGS WOODS SUBDIVISION, SAID POINT ALSO BEING THE SE CORNER OF LOT 14 OF SAID BLOCK F; THENCE N.02°24'32"W. AND ALONG THE EAST LINE OF SILVER SPRINGS WOODS SUBDIVISION A DISTANCE OF 1008.48 FEET TO A POINT ON THE NORTH RIGHT-OF-WAY LINE OF SE 20TH LANE, SAID POINT ALSO BEING THE SE CORNER OF LOT 18, BLOCK E OF THE AFOREMENTIONED SUBDIVISION; THENCE N.87°35'28"E. A DISTANCE OF 420.00 FEET; THENCE N.02°25'07"W. A DISTANCE OF 415.00 FEET; THENCE S.87°35'28"W. A DISTANCE OF 420.00 FEET TO A POINT ON THE EAST LINE OF THE AFOREMENTIONED BLOCK E, SILVER SPRINGS WOODS; THENCE N.02°25'07"W. AND ALONG THE EAST LINE OF SAID BLOCK E AND TRACT "B" A DISTANCE OF 1014.56 FEET TO THE POINT OF BEGINNING, SAID PARCEL LYING AND BEING SITUATED IN THE NE AND SE 1/4'S OF SECTION 24 AND THE NE 1/4 OF SECTION 25, BOTH IN TOWNSHIP 15 SOUTH, RANGE 24 EAST, MARION COUNTY, FLORIDA.

LEASED PREMISES
A PARCEL OF LAND LYING IN SECTION 24, TOWNSHIP 15 SOUTH, RANGE 24 EAST, MARION COUNTY, FLORIDA; SAID PARCEL OF LAND BEING MORE PARTICULARLY DESCRIBED AS FOLLOWS:

COMMENCE AT THE SOUTHEAST CORNER OF LOT 18, BLOCK E, SILVER SPRINGS WOODS, ACCORDING TO THE PLAT THEREOF, AS RECORDED IN PLAT BOOK M, PAGE 81 OF THE PUBLIC RECORDS OF MARION COUNTY, FLORIDA, SAID CORNER ALSO LYING ON THE NORTH RIGHT-OF-WAY LINE OF SE 20TH STREET (A 50' PUBLIC RIGHT-OF-WAY); THENCE N89° 12' 44"E ALONG THE SOUTH LINE OF THOSE LANDS DESCRIBED IN OFFICIAL RECORDS BOOK 3334, PAGE 1034 OF SAID PUBLIC RECORDS FOR 420.00 FEET; THENCE S75° 28' 29"E FOR 45.35 FEET TO THE POINT OF BEGINNING OF THE HEREIN DESCRIBED PARCEL OF LAND; THENCE N89° 12' 09"E FOR 80.00 FEET; THENCE N00° 47' 51"E FOR 80.00 FEET; THENCE S89° 12' 09"W FOR 80.00 FEET; THENCE N00° 47' 51"W FOR 80.00 FEET TO THE POINT OF BEGINNING, SAID PARCEL OF LAND SITUATE, LYING AND BEING IN MARION COUNTY, FLORIDA, CONTAINING 6,400 SQUARE FEET MORE OR LESS.

30' ACCESS AND UTILITY EASEMENT
A 30-FEET WIDE EASEMENT STRIP OF LAND FOR THE PURPOSE OF ACCESS AND UTILITIES LYING IN SECTION 24, TOWNSHIP 15 SOUTH, RANGE 24 EAST, MARION COUNTY, FLORIDA; SAID EASEMENT STRIP OF LAND LYING 15.00 FEET ON BOTH SIDES OF THE FOLLOWING DESCRIBED EASEMENT CENTERLINE:

COMMENCE AT THE SOUTHEAST CORNER OF LOT 18, BLOCK E, SILVER SPRINGS WOODS, ACCORDING TO THE PLAT THEREOF, AS RECORDED IN PLAT BOOK M, PAGE 81 OF THE PUBLIC RECORDS OF MARION COUNTY, FLORIDA, SAID CORNER ALSO LYING ON THE NORTH RIGHT-OF-WAY LINE OF SE 20TH STREET (A 50' PUBLIC RIGHT-OF-WAY); THENCE N89° 12' 44"E ALONG THE SOUTH LINE OF THOSE LANDS DESCRIBED IN OFFICIAL RECORDS BOOK 3334, PAGE 1034 OF SAID PUBLIC RECORDS FOR 420.00 FEET; THENCE S75° 28' 29"E FOR 45.35 FEET, THENCE S00° 47' 51"E FOR 35.00 FEET TO THE POINT OF BEGINNING OF THE HEREIN DESCRIBED EASEMENT CENTERLINE; THENCE S89° 12' 09"W FOR 153.46 FEET; THENCE S66° 00' 54"W FOR 97.96 FEET, TO A NON-TANGENT POINT ON A CURVE; THENCE NORTHWESTERLY FOR 116.61 FEET ALONG THE ARC OF A CURVE, CONCAVE TO THE SOUTHWEST, HAVING A RADIUS OF 100.00 FEET, CENTRAL ANGLE OF 66° 48' 45", SUBTENDED BY A CHORD HAVING A LENGTH OF 110.11 FEET AND BEARING N57° 23' 29"W, TO A POINT OF TANGENCY; THENCE S89° 12' 09"W FOR 128.30 FEET TO AN INTERSECTION WITH THE EAST RIGHT-OF-WAY LINE OF THE AFORESAID SE 20TH STREET AND THE POINT OF TERMINUS, THE SIDELINES OF SAID EASEMENT TO BE SHORTENED AND PROLONGED TO MEET AT ANGLE POINTS, LEASED PREMISES LINES AND RIGHT-OF-WAY LINES.

SURVEYOR'S NOTES
1. BEARINGS SHOWN HEREON ARE GRID NAD83 FLORIDA STATE PLANE, WEST ZONE, ESTABLISHED WITH RTK GPS OBSERVATIONS REFERENCED TO STATE OF FLORIDA PERMANENT REFERENCE NETWORK.

2. THE BOUNDARY & TOPOGRAPHIC SURVEY SHOWN HEREON IS BASED ON ACTUAL FIELD MEASUREMENTS AND OBSERVATIONS DATED OCTOBER 28, 2025.

3. THIS SURVEY MAP OR THE COPIES THEREOF ARE NOT VALID WITHOUT THE SIGNATURE AND THE ORIGINAL RAISED SEAL OF A FLORIDA LICENSED SURVEYOR AND MAPPER.

4. CENTER OF PROPOSED TOWER LATITUDE AND LONGITUDE SHOWN HEREON WERE ESTABLISHED FROM RTK GPS OBSERVATIONS REFERENCED TO THE STATE OF FLORIDA PERMANENT REFERENCE NETWORK. THE VALUES FOR THE PROPOSED TOWER LATITUDE, LONGITUDE AND ELEVATION SHOWN EXCEED FAA "1-A" ACCURACY REQUIREMENTS. ELEVATIONS SHOWN HEREON ARE NAVD 88 AND REFERENCED TO THE FLORIDA DEPARTMENT OF TRANSPORTATION PERMANENT REFERENCE NETWORK (FPRN).

5. THE PURPOSE OF THIS SURVEY IS TO SHOW IMPROVEMENTS ASSOCIATED WITH A PROPOSED TELECOMMUNICATIONS FACILITY AND PROVIDE LEGAL DESCRIPTIONS FOR SAID FACILITY AND ASSOCIATED EASEMENT. THIS IS NOT A SURVEY OF THE PARENT TRACT. PARENT TRACT DATA IS FOR INFORMATION ONLY.

6. MEASURED BEARINGS AND DISTANCES WERE IN SUBSTANTIAL AGREEMENT WITH RECORD DATA UNLESS OTHERWISE NOTED.

7. PROPERTY TIES ARE PERPENDICULAR MEASURE UNLESS OTHERWISE NOTED.

8. UNDERGROUND FOUNDATIONS AND UTILITIES WERE NOT LOCATED AS PART OF THIS SURVEY UNLESS OTHERWISE NOTED HEREON.

9. THE LEASED PREMISES AND THE 30' ACCESS & UTILITY EASEMENT ARE LOCATED ENTIRELY WITHIN THE DESCRIBED PARENT TRACT.

10. THIS SURVEY CONSISTS OF 2 SHEETS. SEE SHEET 2 FOR IMPROVEMENTS, TOPOGRAPHIC DATA AND ADDITIONAL INFORMATION.

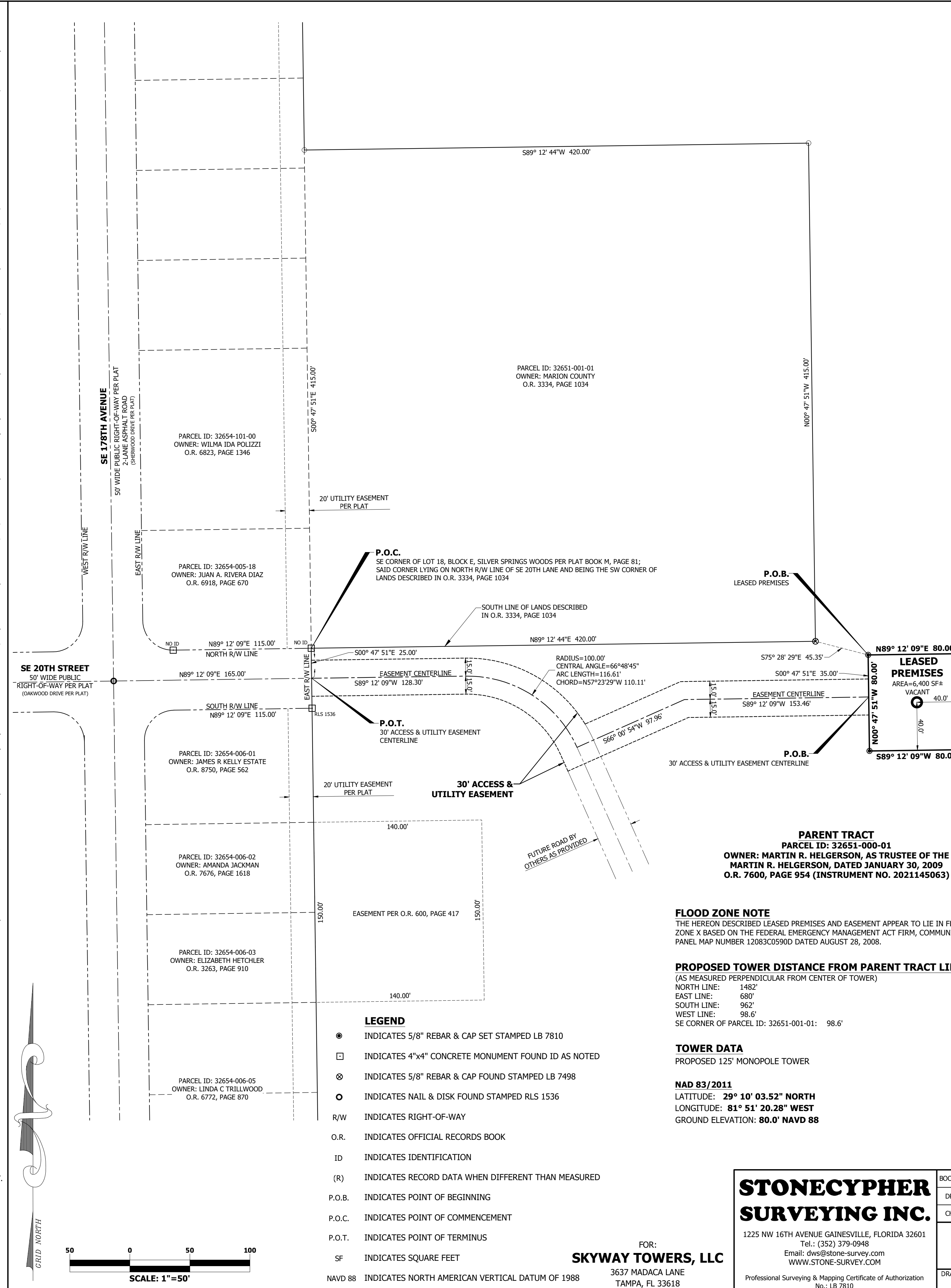

STONECYPHER SURVEYING INC.
1225 NW 16TH AVENUE GAINESVILLE, FLORIDA 32601
Tel.: (352) 379-0948
Email: dws@stone-survey.com
WWW.STONE-SURVEY.COM
Professional Surveying & Mapping Certificate of Authorization No.: LB 7810

BOOK/PAGE	54/28	This map prepared by:	DAVID W. STONECYPHER	SCALE	AS SHOWN
DRAWN	DWS	DATE	11-20-2025	DATE	OCTOBER 28, 2025
CHECKED	DWS	PROJECT #	25-0064	SHEET #	1 OF 2

COMMUNICATION TOWER SITE -- SILVER SPRINGS
NUMBER: SKYWAY FL-01106

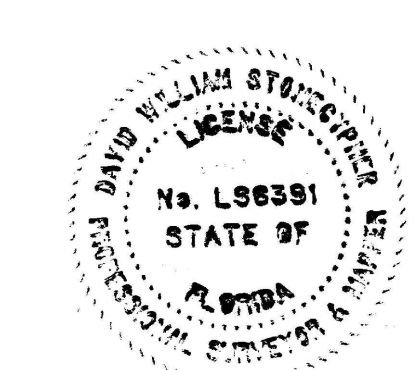

BOUNDARY & TOPOGRAPHIC SURVEY OF SKYWAY TOWERS LEASED PREMISES

IN SECTION 24, TOWNSHIP 15 SOUTH, RANGE 24 EAST,
MARION COUNTY, FLORIDA

PARENT TRACT
PARCEL ID: 32651-000-01
OWNER: MARTIN R. HELGERSON, AS TRUSTEE OF THE
MARTIN R. HELGERSON, DATED JANUARY 30, 2009
O.R. 7600, PAGE 954 (INSTRUMENT NO. 2021145063)

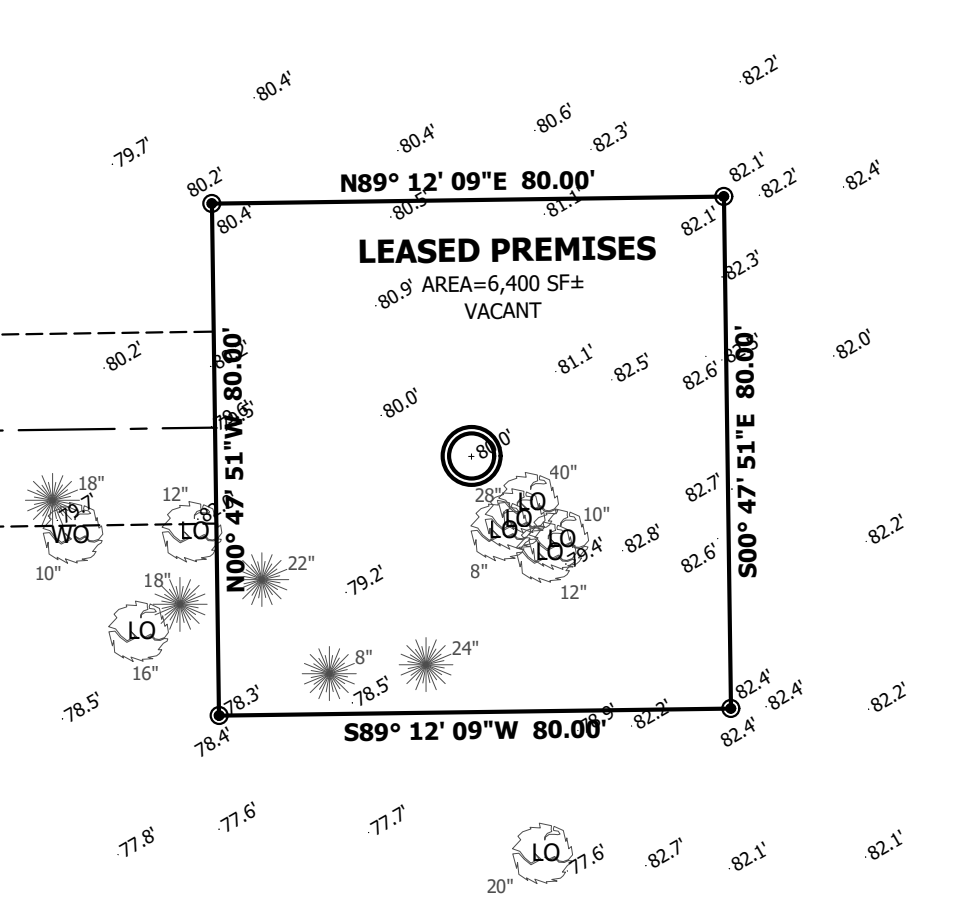
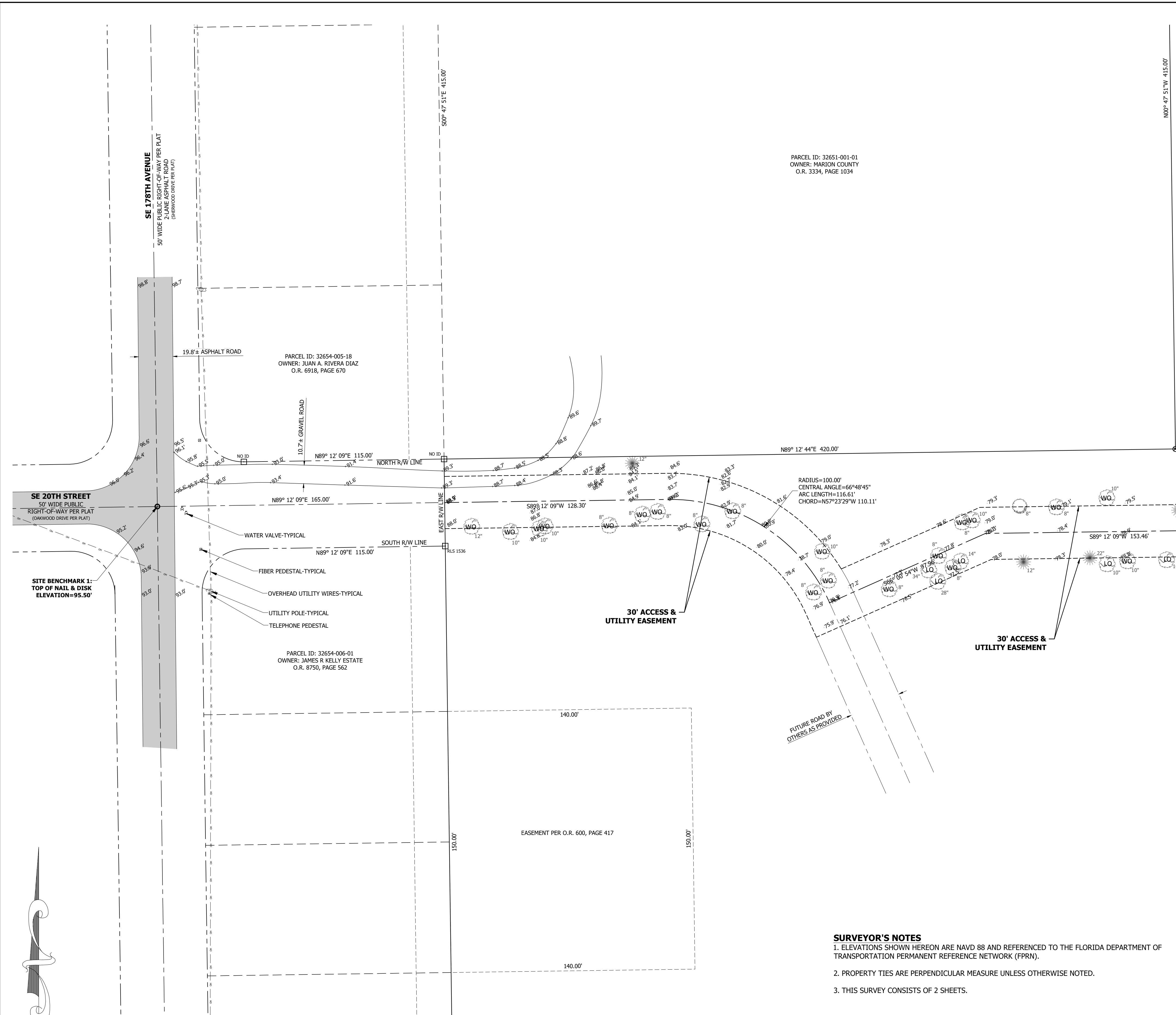

SITE BENCHMARK 1:
TOP OF NAIL & DISK
ELEVATION=95.50'

- WATER VALVE-TYPICAL
- FIBER PEDESTAL-TYPICAL
- OVERHEAD UTILITY WIRES-TYPICAL
- UTILITY POLE-TYPICAL
- TELEPHONE PEDESTAL

SURVEYOR'S NOTES
1. ELEVATIONS SHOWN HEREON ARE NAVD 88 AND REFERENCED TO THE FLORIDA DEPARTMENT OF TRANSPORTATION PHEROMONE REFERENCE NETWORK (FPRN).
2. PROPERTY TIES ARE PERPENDICULAR MEASURE UNLESS OTHERWISE NOTED.
3. THIS SURVEY CONSISTS OF 2 SHEETS.

- LEGEND**
- INDICATES 5/8" REBAR & CAP SET STAMPED LB 7810
 - INDICATES 4"x4" CONCRETE MONUMENT FOUND ID AS NOTED
 - ⊗ INDICATES 5/8" REBAR & CAP FOUND STAMPED LB 7498
 - INDICATES NAIL & DISK FOUND STAMPED RLS 1536
 - R/W INDICATES RIGHT-OF-WAY
 - O.R. INDICATES OFFICIAL RECORDS BOOK
 - ID INDICATES IDENTIFICATION
 - (R) INDICATES RECORD DATA WHEN DIFFERENT THAN MEASURED
 - P.O.B. INDICATES POINT OF BEGINNING
 - P.O.C. INDICATES POINT OF COMMENCEMENT
 - P.O.T. INDICATES POINT OF TERMINUS
 - SF INDICATES SQUARE FEET
 - NAVD 88 INDICATES NORTH AMERICAN VERTICAL DATUM OF 1988
 - 85.4 INDICATES EXISTING SPOT ELEVATION

- TREE LEGEND**
- CHERRY TREE
 - LIVE OAK TREE
 - WATER OAK TREE
 - PINE TREE
 - 14" INDICATES TREE DIAMETER
 - 18"+18"+18" INDICATES TREE DIAMETERS OF TREE CLUSTER
 - ALL TREES 8"+ WITHIN THE LEASED PREMISES AND EASEMENTS WERE LOCATED AND ARE DEPICTED HEREON

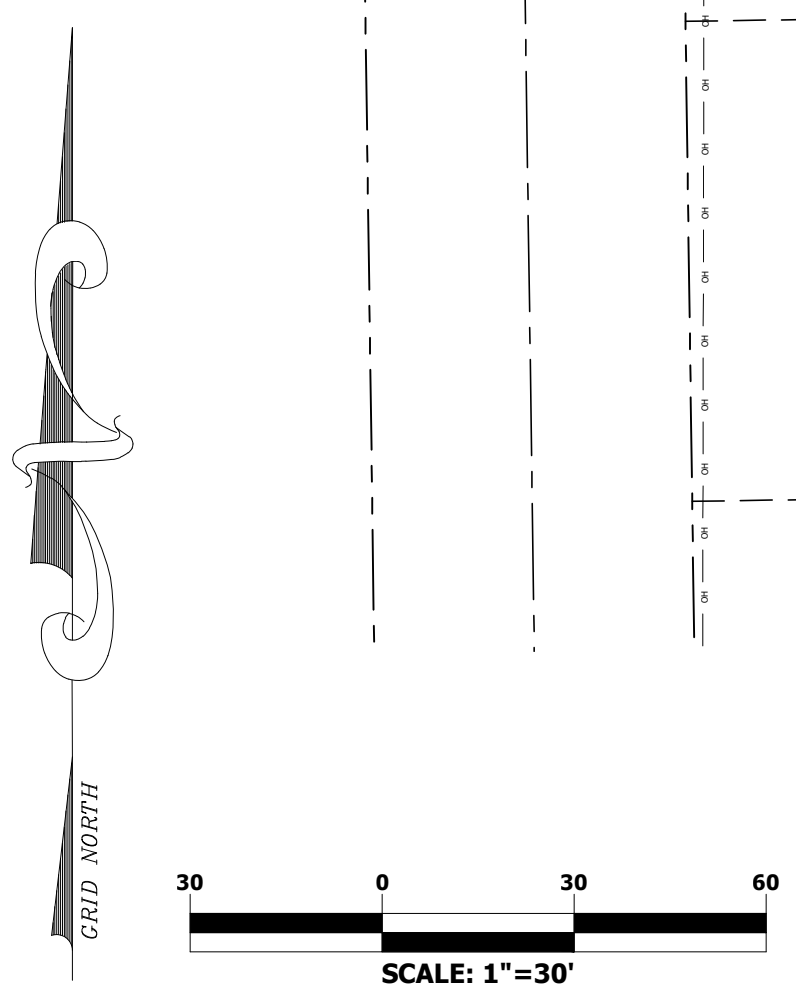

FOR:
SKYWAY TOWERS, LLC
3637 MADACA LANE
TAMPA, FL 33618

STONECYPHER SURVEYING INC. 1225 NW 16TH AVENUE GAINESVILLE, FLORIDA 32601 Tel.: (352) 379-0948 Email: dws@stone-survey.com WWW.STONE-SURVEY.COM Professional Surveying & Mapping Certificate of Authorization No.: LB 7810	BOOK/PAGE	54/28	SCALE	1" = 30'
	DRAWN	DWS	DATE	OCTOBER 28, 2025
	CHECKED	DWS	PROJECT #	25-0064
COMMUNICATION TOWER SITE -- SILVER SPRINGS NUMBER: SKYWAY FL-01106			DRAWING #	FL-01106.SURVEY.DWG
			SHEET #	2 OF 2

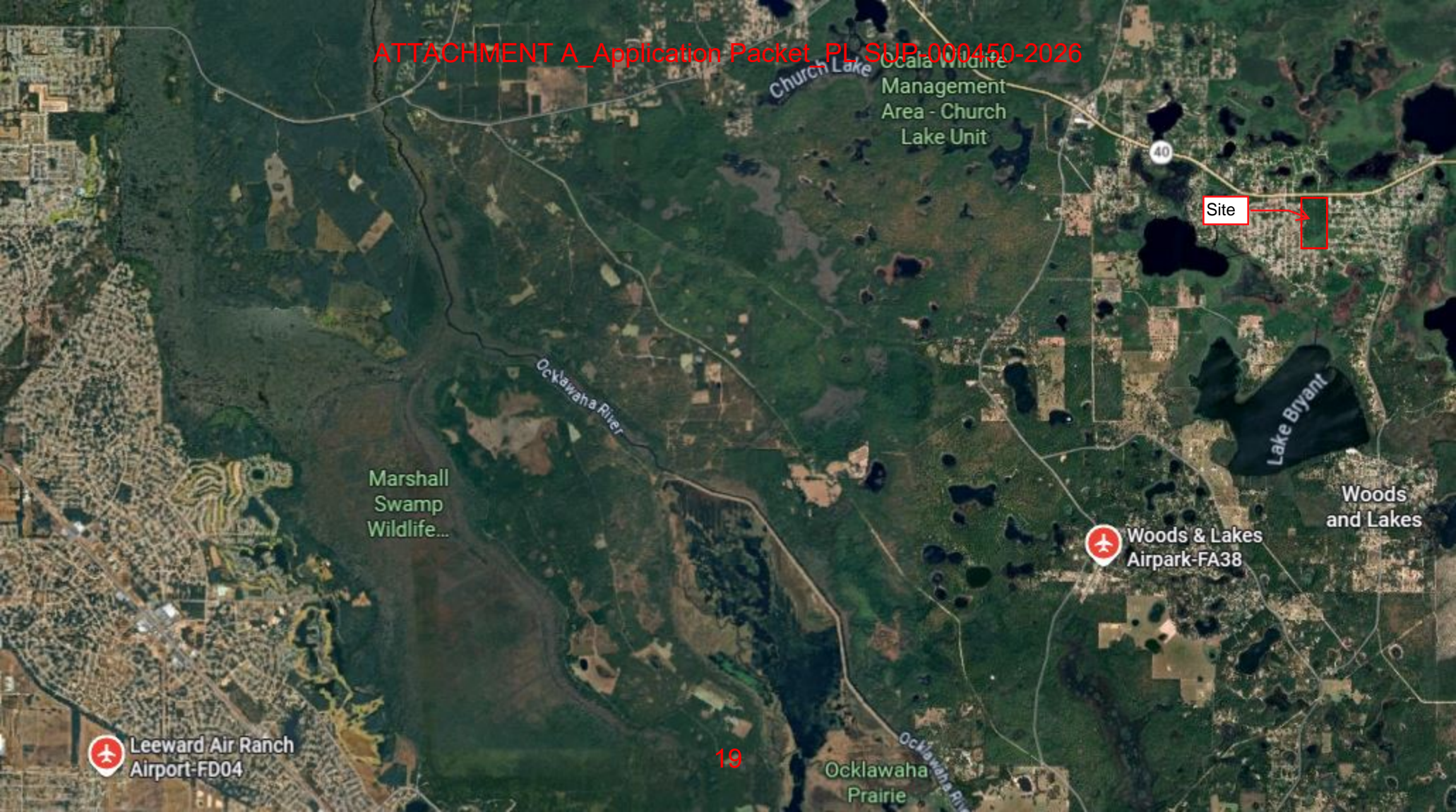

ATTACHMENT A_Application Packet_PL SUP-000450-2026

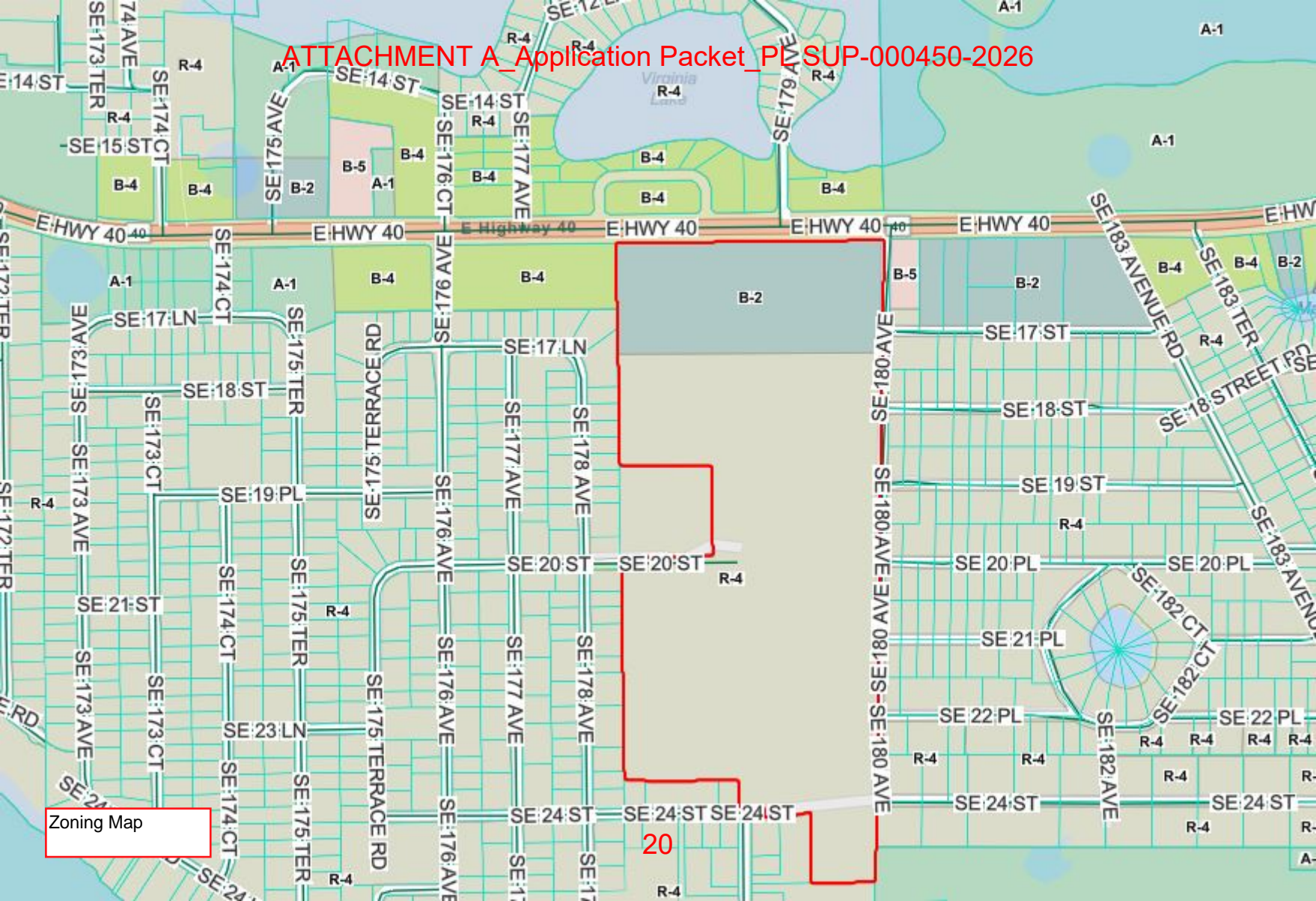

Zoning Map

20

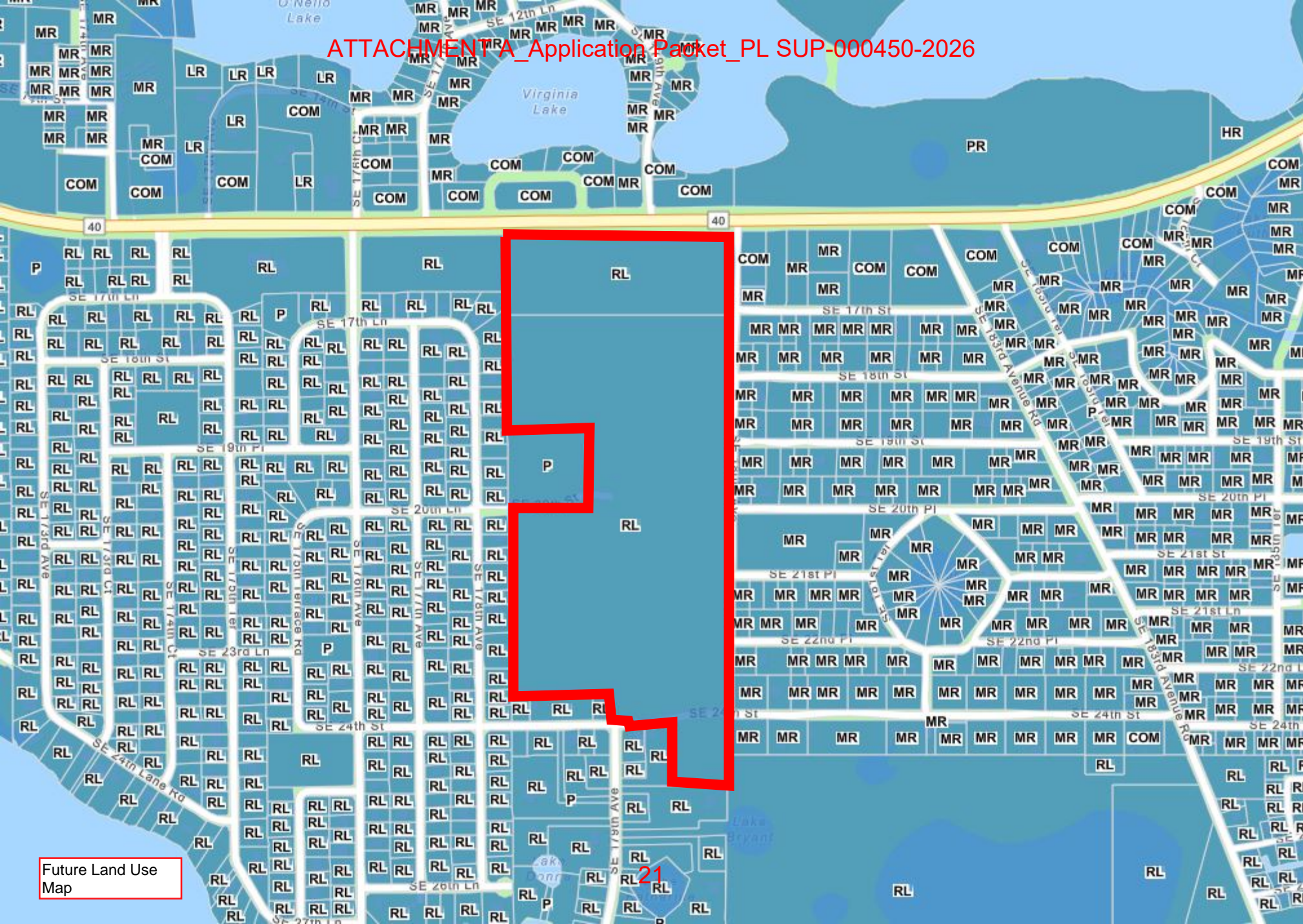

Future Land Use Map

21

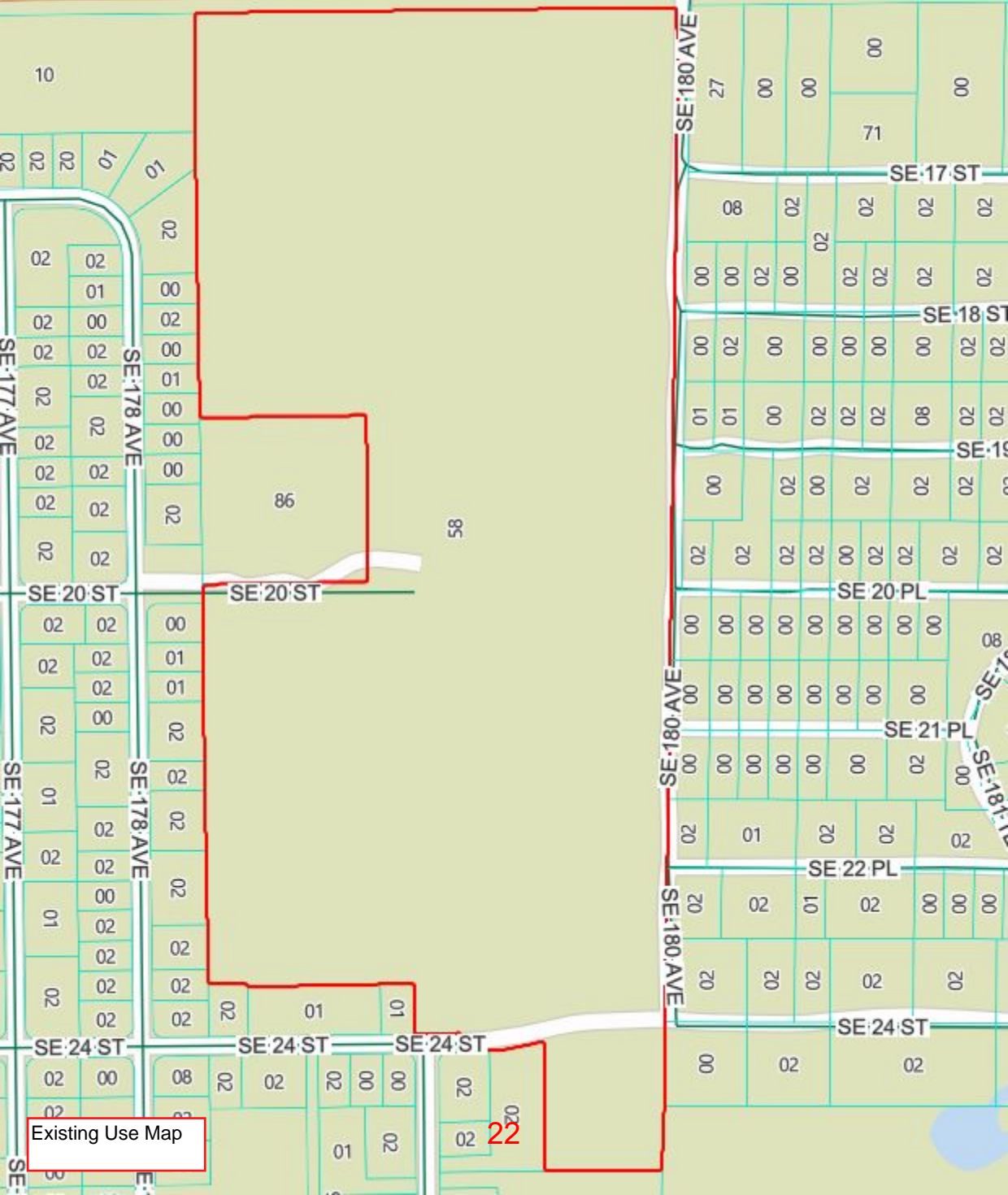

Existing Use Map

22



Aerial Map



A2D0418A Pre and Post Propagations

Existing and Proposed Sites

Ring:

A2D0418 Lat: 29.167235 Long: -81.853616 ACL: 180ft

Proposed site:

A2D0418A Lat: 29.167644 Long: -81.855633 ACL: 120ft

Existing sites:



A2C0203E Lat: 29.188177 Long: -81.881779 ACL: 258ft

A2C1014A Lat: 29.185004 Long: -81.773032 ACL: 260ft

A2C6202S Lat: 29.135292 Long: -81.891795 ACL: 153ft

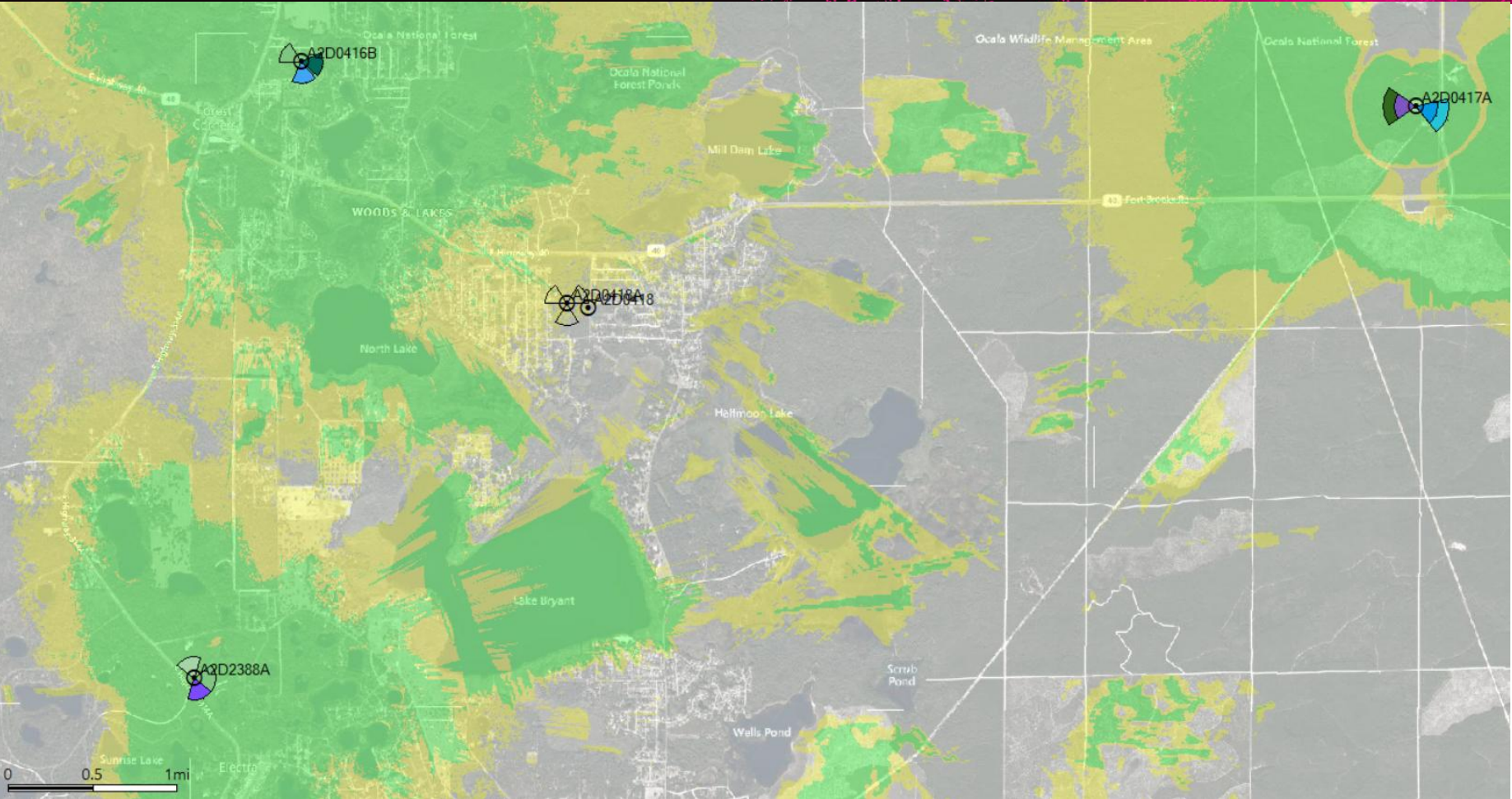

5G Coverage Without A2D0418A Mid-Band (B25-1900MHz) NR Service Map (RSRP)

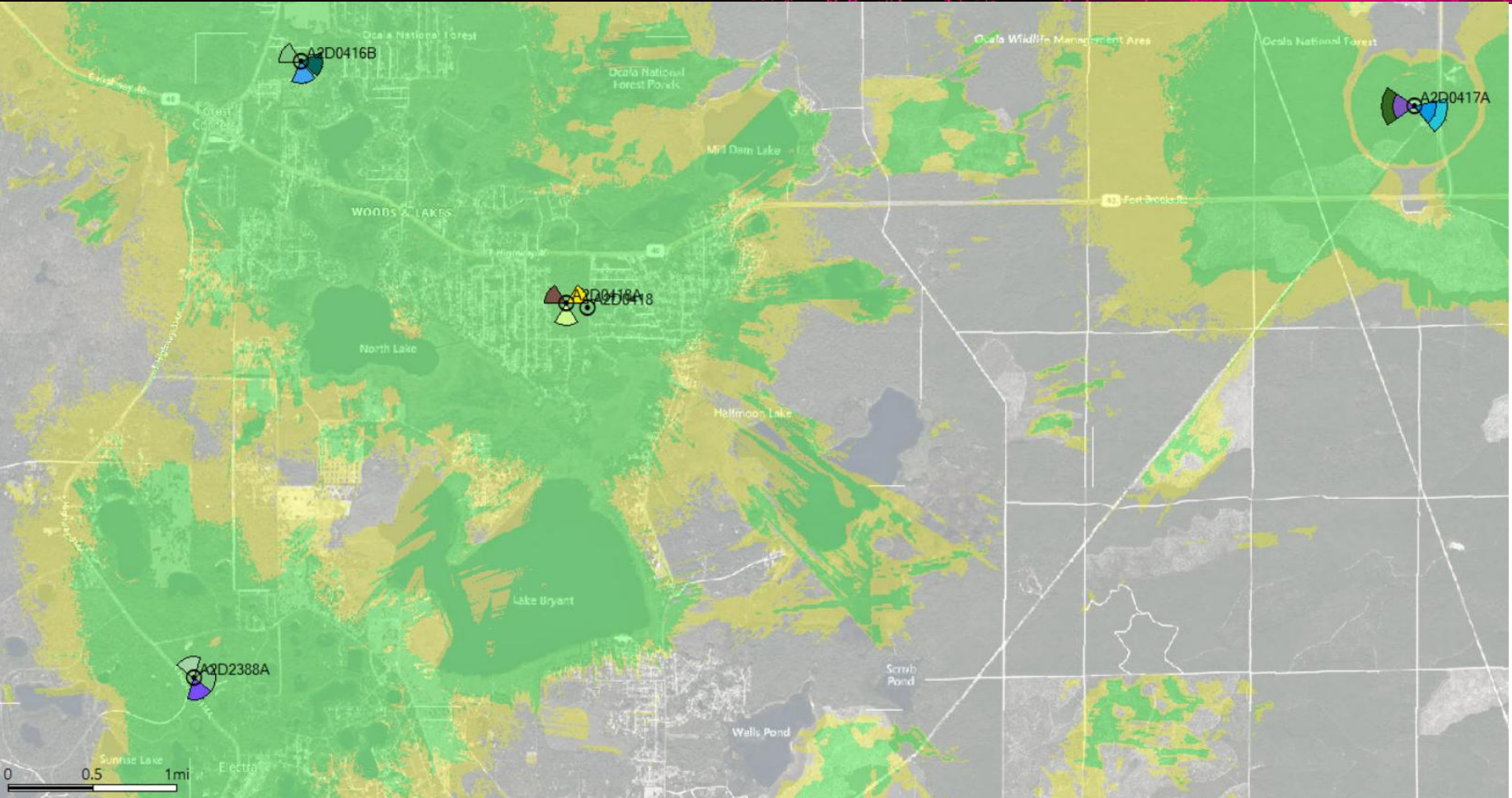

-  Reliable 5G In-Building Residential Coverage (≥ -94 dBm)
-  Reliable 5G In Vehicle Coverage ($-94 > X > -102$ dBm)

5G Coverage With A2D0418A Mid-Band (B25-1900MHz) NR Service Map (RSRP)



-  Reliable 5G In-Building Residential Coverage (≥ -94 dBm)
-  Reliable 5G In Vehicle Coverage ($-94 > X > -102$ dBm)

Thank You

NEW WIRELESS COMMUNICATION TOWER
INTENT TO ALLOW COLLOCATION AFFIDAVIT

BEFORE ME, the undersigned authority, personally appeared Justin Jones, who being by me first duly sworn, under oath, deposes and states as follows:

1. I am over eighteen (18) years of age and have personal knowledge of the matters contained herein.
2. I am the Vice President of Skyway Towers, LLC and have the authority to sign this affidavit.
3. It is the intent of Skyway Towers, LLC to construct a Wireless Communication Tower ("WCT") on parcel no. 32651-000-01 in Marion County.
4. The WCT will be designed to collocate up to four (4) sets of wireless communication antennas ("WCA") upon it.
5. It is the intent of Skyway Towers, LLC and its successors to allow collocation of WCAs at a reasonable market rate or to allow a replacement tower to be erected within the WCT Area provided that the replacement is physically and contractually feasible and that the cost of modifying or replacing the WCT to accommodate the collocated WCA is borne by the collocating company.

FURTHER AFFIANT SAYETH NOT.



Skyway Towers, LLC

By: Justin Jones

Its: Vice President

STATE OF FLORIDA

COUNTY OF HILLSBOROUGH

The foregoing instrument was acknowledged before me by means of physical presence or online notarization, this 5th day of January, 2026, by Justin Jones, who is personally known to me or who has produced _____ as identification.

[AFFIX NOTARY SEAL OR STAMP]

Name:

My Commission Expires:
MAY 31st 2029

- ←
- [Home](#)
- [Dashboard](#)
- [Reports](#)
- [Search](#)
- [Download](#)
- [Pre-Screening Tool](#)
- [Tools](#)
- [FAQ & Resources](#)

File Notice

My Recent Activity

Form Approved OMB No.2120-0001
Expiration Date: 05/31/2026

Privacy Act Statement (5 U.S.C. § 552a(e)(3)): Authority: Information solicited by the Federal Aviation Administration (FAA) Obstruction Evaluation/Airport Airspace Analysis (OE/AAA) is authorized by 49 U.S.C. § 44718 and 47101 Purpose: The FAA OE/AAA is an application used to evaluate all structures that may affect the national airspace system and defend against potential hazards to the safety and efficient use of the navigable airspace. The information collected is used to allow a user access to the OE/AAA and to administer the Aeronautical Study Process. Routine Uses: In accordance with the Privacy Act system of records notice, DOT/ALL 16 Mailing Management System and DOT/FAA 826 Petitions for Exemptions, Other than Medical Exemptions this information may be disclosed to officials within the federal government and the public in general. DOT/ALL 13 - Internet/Intranet Activity and Access Records, this information is routinely used; • To provide information to any person(s) authorized to assist in an approved investigation of improper access or usage of DOT computer systems; • To an actual or potential party or his or her authorized representative for the purpose of negotiation or discussion of such matters as settlement of the case or matter, or informal discovery proceedings; • To contractors, grantees, experts, consultants, detailees, and other non-DOT employees performing or working on a contract, service, grant cooperative agreement, or other assignment from the Federal government, when necessary to accomplish an agency function related to this system of records; and • To other government agencies where required by law.

Disclosure: Submission of the information is voluntary, however, failure to submit requested information will result in FAA's inability to grant you access to the system and may result in an inability of the FAA to process the notice or administer the aeronautical study process for the construction, alteration, activation, or deactivation proposed.

 U.S. Department of Transportation Federal Aviation Administration	<i>Failure to Provide All Requested Information May Delay Processing of your Notice</i> Notice of Proposed Construction or Alteration	FOR FAA USE ONLY Aeronautical Study Number 2026-ASO-898-OE Status: Studying
--------------------------------------------------------------------------------------------------------------------------------------------------------------------	-----------------------------------------------------------------------------------------------------------------------------------------------------	----------------------------------------------------------------------------------------------

<p>1. Sponsor</p> <p>Name: Skyway Towers, LLC Attn of: Operations Address: 3637 Madaca Lane City: Tampa State: FL Zip: 33618 Country: US Phone: tel:+1-813-960-6200 Fax:</p> <p>2. Sponsor's Representative</p> <p>Name: Skyway Towers, LLC Attn of: Katrina McCarron Address: 3637 Madaca Ln. City: Tampa State: FL Zip: 33618 Country: US Phone: tel:+1-813-960-6200 Fax:</p> <p>3. Notice of: Construction</p> <p>4. Duration: Permanent (Months: Days:)</p> <p>5. Work Schedule: N/A</p> <p>6a. Type: Antenna Tower 6b. Name: FL-01106 Silver Springs</p> <p>7. Preferred Marking/Lighting: Not Marked/No Lighting Current Marking/Lighting:</p> <p>8. FCC Antenna Registration Number (if applicable): _____</p>	<p>9. Latitude: See Collected Point(s)</p> <p>10. Longitude: See Collected Point(s)</p> <p>11. Datum: See Collected Point(s)</p> <p>12. Nearest: City: Silver Springs State: Florida</p> <p>13. Nearest Public-use or Military Airport or Heliport: UF HEALTH SPANISH PLAINES HOSPITAL(FL20)</p> <p>14. Distance from #13. to Structure: 85958 ft.</p> <p>15. Direction from #13. to Structure: 23 deg</p> <p>16. Site Elevation (SE): See Collected Point(s)</p> <p>17. Structure Height (AGL): See Collected Point(s)</p> <p>18. Overall Height (#16 + #17) (AMSL): See Collected Point(s) Current Overall Height (#16 + #17) (AMSL): See Collected Point(s)</p> <p>19. Previous FAA Aeronautical Study Number (if applicable): _____</p> <p>20. Description of Location: SE 24th St Silver Springs, FL 32179 (Marion county)</p> <div style="text-align: right;">  </div> <p>Processed 7460-2 Forms : Supplemental Form 7460-2 : Add 7460-2</p>
----------------------------------------------------------------------------------------------------------------------------------------------------------------------------------------------------------------------------------------------------------------------------------------------------------------------------------------------------------------------------------------------------------------------------------------------------------------------------------------------------------------------------------------------------------------------------------------------------------------------------------------------------------------------------------------------------------------------------------------------------------------------------------------------------------------------------------------------------------------------------------------------------------------------------------------------------------------------------------------------------------------------------------	------------------------------------------------------------------------------------------------------------------------------------------------------------------------------------------------------------------------------------------------------------------------------------------------------------------------------------------------------------------------------------------------------------------------------------------------------------------------------------------------------------------------------------------------------------------------------------------------------------------------------------------------------------------------------------------------------------------------------------------------------------------------------------------------------------------------------------------------------------------------------------------------------------------------------------------------------------------------------------------------------------------------------------------------------------------------------------------------------------------------------------------------------------------------------------------------------------

	Frequencies: 30	Specific Frequencies:
--	---------------------------------------------------------------------------------------	-----------------------

21. Description of

Proposal:

Proposed 125' Self support tower with a 4' rod for an overall height of 129'

LOW ↓	HIGH ↓	ERP
6	7 GHz	42 dBW
6	7 GHz	55 dBW
10	11.7 GHz	42 dBW
10	11.7 GHz	55 dBW
17.7	19.7 GHz	42 dBW
17.7	19.7 GHz	55 dBW
21.2	23.6 GHz	42 dBW
21.2	23.6 GHz	55 dBW
614	698 MHz	1000 W
614	698 MHz	2000 W
698	806 MHz	1000 W
806	824 MHz	500 W
806	901 MHz	500 W
824	849 MHz	500 W
851	866 MHz	500 W
869	894 MHz	500 W
896	901 MHz	500 W
901	902 MHz	7 W
929	932 MHz	3500 W
930	931 MHz	3500 W
931	932 MHz	3500 W
932	932.5 MHz	17 dBW
935	940 MHz	1000 W
940	941 MHz	3500 W
1670	1675 MHz	500 W
1710	1755 MHz	500 W
1850	1910 MHz	1640 W
1850	1990 MHz	1640 W
1930	1990 MHz	1640 W
1990	2025 MHz	500 W
2110	2200 MHz	500 W
2305	2360 MHz	2000 W
2305	2310 MHz	2000 W
2345	2360 MHz	2000 W

LOW ↓	HIGH ↓	ERP
-------	--------	-----

LOW	HIGH	ERP
2496	2690 MHz	500 W

Collected Point(s):

Label	Latitude	Longitude	Datum	AGL	SE	SE Validation	SE Comments
pt-1	29 10 03.52N	81 51 20.28W	NAD83	129 ft	80 ft	PASSED	

Notice is required by 14 Code of Federal Regulations, part 77 pursuant to 49 U.S.C., Section 44718. Persons who knowingly and willingly violate the notice requirements of part 77 are subject to a civil penalty of \$1,000 per day until the notice is received, pursuant to 49 U.S.C., Section 46301(a)

I hereby certify that all of the above statements made by me are true, complete, and correct to the best of my knowledge. In addition, I agree to mark and/or light the structure in accordance with established marking & lighting standards as necessary.

This FAA Form 7460-1 was submitted electronically on 01/14/2026 at 11:32 AM EST.

Add Document

Title	Type	File	
1A Survey		Skyway Towers_FL-01106_Silver Springs.1A letter.pdf	
			<input type="button" value="DONE"/> <input type="button" value="X"/>

Letter	Date

Michael F. Plahovinsak, P.E.

18301 State Route 161, Plain City, Ohio 43064

(614) 398-6250 - mike@mfpeng.com

January 14, 2026

Skyway Towers
3637 Madaca Lane
Tampa, FL 33618

Re: Proposed 125-ft Monopole
Located in Marion Co., FL: FL-01106 Silver Springs
MFP Project #: 30326-003

I understand that there may be some concern on the part of local building officials regarding the potential for failure of the proposed communication monopole. Communication structures are designed in accordance with the Telecommunications Industry Association TIA-222-H, "Structural Standards for Steel Antenna monopoles and Antenna Supporting Structures".

I will design this monopole to withstand a 3-sec. gusted wind speed of 130 mph as recommended by TIA-222-H for Marion Co., FL. The design will also conform to the requirements of the Florida Building Code (8th Ed. 2023).

This monopole will be designed to accommodate a theoretical fall radius within the lease area compound. The upper sections of the monopole will be designed to meet the wind loads of the design, however, the lower portion of the monopole will be designed with a minimum 10% extra capacity. Assuming the monopole has been fabricated according to my design, and well maintained, in the event of a failure due to extreme wind and comparable appurtenance antenna load (winds in excess of the design wind load), it would yield/buckle at the weakest section. The yielded upper sections are designed to collapse within the 80' x 80' lease area.

The structure will be designed with all of the applicable factors as required by the code. Telecommunication towers are safe structures with a long history of reliable operation.

I hope this review of the tower design has given you a greater degree of comfort regarding the design capacity inherent in tower structures. If you have any additional questions please call me at 614-398-6250 or email mike@mfpeng.com.

Sincerely,

Michael F. Plahovinsak, P.E.



Michael F. Plahovinsak, P.E.
Sole Proprietor - Independent Engineer
P.E. Licensed in 48 Jurisdictions





Antenna Structure Registration

[FCC](#) > [WTB](#) > [ASR](#) > [Online Systems](#) > TOWAIR

[FCC Site Map](#)

TOWAIR Determination Results

[? HELP](#)

[New Search](#) [Printable Page](#)

*** NOTICE ***

TOWAIR's findings are not definitive or binding, and we cannot guarantee that the data in TOWAIR are fully current and accurate. In some instances, TOWAIR may yield results that differ from application of the criteria set out in 47 C.F.R. Section 17.7 and 14 C.F.R. Section 77.13. A positive finding by TOWAIR recommending notification should be given considerable weight. On the other hand, a finding by TOWAIR recommending either for or against notification is not conclusive. It is the responsibility of each ASR participant to exercise due diligence to determine if it must coordinate its structure with the FAA. TOWAIR is only one tool designed to assist ASR participants in exercising this due diligence, and further investigation may be necessary to determine if FAA coordination is appropriate.

DETERMINATION Results

Structure does not require registration. There are no airports within 8 kilometers (5 miles) of the coordinates you provided.

Your Specifications

NAD83 Coordinates

Latitude	29-10-03.5 north
Longitude	081-51-20.3 west

Measurements (Meters)

Overall Structure Height (AGL)	39.3
Support Structure Height (AGL)	38.1
Site Elevation (AMSL)	24.4

Structure Type

MTOWER - Monopole

Tower Construction Notifications

Notify Tribes and Historic Preservation Officers of your plans to build a tower.

ASR Help

[FAQ](#) - [Online Help](#) - [Documentation](#) - [Technical Support](#)

ASR Online Systems

[TOWAIR](#) - [CORES](#) - [ASR Online Filing](#) - [Application Search](#) - [Registration Search](#)

About ASR

[Privacy Statement](#) - [About ASR](#) - [ASR Home](#)

[FCC](#) | [Wireless](#) | [ULS](#) | [CORES](#)

[Help](#) | [Tech Support](#)

Federal Communications Commission
45 L Street NE
Washington, DC 20554

Phone: 1-877-480-3201
ASL Videophone: 1-844-432-2275
[Submit Help Request](#)



Wednesday, February 19, 2025

To Whom It May Concern:

Subject: T-Mobile FCC compliance

T-Mobile will comply with all FCC rules regarding interference to other radio services and T-Mobile will comply with all FCC rules regarding human exposure to radio frequency.

From the FCC Web site:

The RF emissions from cellular or PCS base station antennas are generally directed toward the horizon in a relatively narrow pattern in the vertical plane. In the case of sector (panel) antennas, the pattern is fan-shaped, like a wedge cut from a pie. As with all forms of electromagnetic energy, the power density from the antenna decreases rapidly as one moves away from the antenna. Consequently, ground-level exposures are much less than exposures if one were at the same height and directly in front of the antenna.

Measurements made near typical cellular and PCS installations, especially those with tower-mounted antennas, have shown that ground-level power densities are hundreds to thousands of times less than the FCC's limits for safe exposure. This makes it extremely unlikely that a member of the general public could be exposed to RF levels in excess of FCC guidelines due solely to cellular or PCS base station antennas located on towers or monopoles.

Please do not hesitate to contact me with any questions or concerns regarding this.

Respectfully,

A handwritten signature in blue ink that reads "Jason Paulley".

Jason Paulley
RF Engineer, T-Mobile
jason.paulley@t-mobile.com
Phone: 321-280-9987

Prepared by and Return to:

Sean Walsh
Skyway Towers, LLC
3637 Madaca Lane
Tampa, FL 33618
Attn: Property Management
Phone: (813) 960-6214

State: FLORIDA
County: MARION
APN: 32651-000-01

MEMORANDUM OF AGREEMENT

This Memorandum of Agreement is entered into on this 8th day of October, 2025, by and between Martin R. Helgerson, as Trustee of the Martin R. Helgerson Trust, dated January 30, 2009, with a mailing address of 5750 NE 36th Avenue Road, Ocala, Florida 34479-1990 (hereinafter referred to as "**Landlord**") and Skyway Towers, LLC, a Delaware limited liability company, having a mailing address of 3637 Madaca Lane, Tampa, Florida 33618 (hereinafter referred to as "**Tenant**").

1. Landlord and Tenant entered into a certain Option and Lease Agreement ("**Agreement**") on the 8th day of October, 2025, for the purpose of installing, operating, and maintaining a Communications Tower Facility and other improvements. The property is more fully described in **Exhibit 1** attached hereto and made a part hereof (the "**Property**"). All of the foregoing is set forth in the Agreement.
2. The initial term will be five (5) years ("**Initial Term**") commencing on the Commencement Date, with ten (10) successive five (5) year renewal options.
3. In the event Landlord receives a bona fide written offer to sell, assign or transfer Landlord's interest under the Agreement and/or the Landlord's rights to receive rents under the terms of the Agreement (the "**Rental Stream Offer**"), Tenant retains a right of first refusal to match the Rental Stream Offer.
4. This Memorandum of Agreement is not intended to amend or modify, and shall not be deemed or construed as amending or modifying, any of the terms, conditions or provisions of the Agreement, all of which are hereby ratified and affirmed.
5. In the event of a conflict between the provisions of this Memorandum of Agreement and the provisions of the Agreement, the provisions of the Agreement shall control.
6. The Agreement shall be binding upon and inure to the benefit of the parties and their respective heirs, successors, and assigns, subject to the provisions of the Agreement.

[REMAINDER OF PAGE INTENTIONALLY LEFT BLANK]
[SIGNATURE AND ACKNOWLEDGMENT FOLLOW ON NEXT PAGES]

IN WITNESS WHEREOF, the parties have executed this Memorandum of Agreement as of the day and year first above written.

WITNESSES:

"LANDLORD"

Martin R. Helgerson, as Trustee of the Martin R. Helgerson, dated January 30, 2009

Rebecca Helgerson
Printed Name Rebecca Helgerson
Address 5750 NE 31st Ave Rd.
Ocala, FL 34479

By: *Martin R. Helgerson*
Name: Martin R. Helgerson
Title: Trustee
Date: 9-25-25

Rochelle Paten
Printed Name Rochelle Paten
Address 203 S. Ferry St
Orlando FL 32801

State of Iowa

LANDLORD ACKNOWLEDGMENT

STATE OF FLORIDA)
COUNTY OF Wapello) ss:

I CERTIFY that on September 25, 2025 Martin R. Helgerson [name of representative] personally came before me and acknowledged under oath that he or she:

- (a) is the Trustee [title] of the the Martin R. Helgerson, dated January 30, 2009, the Trust named in the attached instrument,
- (b) is authorized to execute this instrument on behalf of Trust; and
- (c) executed the instrument as the act of the Trust.

[Affix Notary Seal]

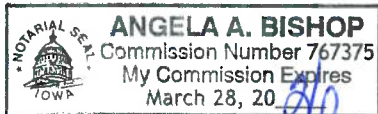

Angela A. Bishop
Notary Public State of Florida, *Notary Public*
Print Name: Angela A. Bishop *State of Iowa*
My Commission Expires: March 28, 2026

[TENANT SIGNATURE AND ACKNOWLEDGMENT FOLLOW ON NEXT PAGE]

WITNESSES:

"TENANT"

Skyway Towers, LLC,
a Delaware limited liability company

Print Name: Stephen Aruz
Address: 3637 Madaca Lane
Tampa, Florida 33618

By: 
Name: Scott M. Behuniak
Title: President / COO
Date: 10-8-25



Print Name: KATRINA MCCARRON
Address: 3637 Madaca Lane
Tampa, Florida 33618

TENANT ACKNOWLEDGMENT

STATE OF FLORIDA)
) ss:
COUNTY OF HILLSBOROUGH)

The foregoing instrument was acknowledged before me this 8th day of October, 2025, by Scott M. Behuniak, as President / COO of Skyway Towers, LLC, a Delaware limited liability company, on behalf of the company, who appeared and is personally known to me.
[Affix Notary Seal]

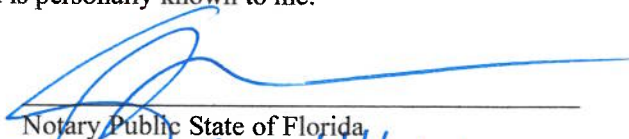
 **SEAN WALSH**
Notary Public
State of Florida
Comm# HH250163
Expires 4/6/2026

Notary Public State of Florida
Print Name: Sean Walsh
My Commission Expires: 4/6/2026

**EXHIBIT 1
DESCRIPTION OF THE PROPERTY**

The Property is located off SE 24th Street, Silver Springs, in the County of Marion, State of Florida 34488, and described as follows:

Property ID: 32651-000-01

[INSERT DEED OR LEGAL DESCRIPTION]

Commence at the NE corner of TRACT "B", SILVER SPRINGS WOODS as found in Plat Book "M" at Page 81, Public Records of Marion County, Florida, said point being on the south right-of-way line of State Road 40 (132 foot wide) and also the Point of Beginning; Thence N.87°35'14"E. and along said south right-of-way line a distance of 1221.47 feet to the intersection of the East boundary line of the NE 1/4 of Section 24, Township 15 South, Range 24 East and the south right-of-way line of State Road 40; Thence S.02°43'09"E. and along said East line of the NE 1/4 of Section 24 a distance of 140.79 feet to the East 1/4 corner of said Section 24; Thence S.00°47'13"E. and along the East line of the SE 1/4 of said Section 24 a distance of 2619.11 feet to the SE corner of said Section 24, also being the NE corner of Section 25, Township 15 South, Range 24 East, Thence S.00°57'33"E. and along the East line of the NE 1/4 of said Section 25 a distance of 160.09 feet; Thence S.87°33'12"W, a distance of 295.56 feet; Thence N.02°26'36"W. a distance of 326.33 feet to a point on a curve concaving northerly having a 880.17 foot radius, chord of 215.05 feet and chord bearing of S.80°33'57"W.; Thence along the arc of said curve a distance of 215.59 feet; Thence N.02°26'46"W. a distance of 49.96 feet; Thence S.87°36'06"W. a distance of 114.68 feet; Thence N.02°24'23"W, a distance of 124.98 feet; Thence S.87°35'16"W. a distance of 419.94 feet; Thence N.02°36'22"W. a distance of 6.15 feet; Thence S.87°30'09"W. a distance of 99.95 feet to a point on the East line of Block F of the aforementioned SILVER SPRINGS WOODS subdivision, said point also being 131.00 feet north of the SE corner of Lot 14 of said Block F; Thence N.02°24'32"W. and along the East line of SILVER SPRINGS WOODS subdivision a distance of 1008.48 feet to a point on the north right-of-way line of SE 20th Lane, said point also being the SE corner of Lot 18, Block E of the aforementioned subdivision; Thence N.87°35'28"E. a distance of 420.00 feet; Thence N.02°25'07"W. a distance of 415.00 feet; Thence S.87°35'28"E. a distance of 420.00 feet to a point on the East line of the aforementioned Block E, SILVER SPRINGS WOODS; Thence N.02°25'07"W. and along the East line of said Block E and TRACT "B" a distance of 1014.56 feet to the Point of Beginning. Said parcel lying and being situated in the NE and SE 1/4's of Section 24 and the NE 1/4 of Section 25, both in Township 15 South, Range 24 East, Marion County, Florida.

Note:

This Exhibit may be supplemented or replaced by full legal description based upon a land survey of the Property once a land survey is received by Tenant.



Prepared by
Belinda Stephenson, an employee of
First American Title Insurance Company
1808 East Silver Springs Blvd
Ocala, Florida 34470
(352)690-1787

Return to: Grantee

File No.: 14203-2718125

WARRANTY DEED

THIS INDENTURE, executed on **October 15, 2021**, between

Schantz Scott

whose mailing address is: P. O. Box 11956, Atlanta, GA 30355-1956,
hereinafter called the "grantor", and

Martin R. Helgerson, as Trustee of the Martin R. Helgerson, dated January 30, 2009

whose mailing address is: , 5750 NE 36th Ave. Rd . Ocala, FL 34479
hereinafter called the "grantee":

(Which terms "Grantor" and "Grantee" shall include singular or plural, corporation or individual, and either sex, and shall include heirs, legal representatives, successors and assigns of the same)

WITNESSETH: The grantor, for and in consideration of the sum of \$10.00 and other good and valuable consideration, receipt whereof is hereby acknowledged, by these presents does grant, bargain, release, convey and confirms unto the grantee, their heirs and assigns, all that certain land situate in **Marion** County, **FL**, to-wit:

Commence at the NE corner of TRACT "B", SILVER SPRINGS WOODS as found in Plat Book "M" at Page 81, Public Records of Marion County, Florida, said point being on the south right-of-way line of State Road 40 (132 foot wide) and also the Point of Beginning; Thence N.87°35'14"E. and along said south right-of-way line a distance of 1221.47 feet to the intersection of the East boundary line of the NE 1/4 of Section 24, Township 15 South, Range 24 East and the south right-of-way line of State Road 40; Thence S.02°43'09"E. and along said East line of the NE 1/4 of Section 24 a distance of 140.79 feet to the East 1/4 corner of said Section 24; Thence S.00°47'13"E. and along the East line of the SE 1/4 of said Section 24 a distance of 2619.11 feet to the SE corner of said Section 24, also being the NE corner of Section 25, Township 15 South, Range 24 East, Thence S.00°57'33"E. and along the East line of the NE 1/4 of said Section 25 a distance of 160.09 feet; Thence S.87°33'12"W, a distance of 295.56 feet; Thence N.02°26'36"W. a distance of 326.33 feet to a point on a curve concaving northerly having a 880.17 foot radius, chord of 215.05 feet and chord bearing of S.80°33'57"W.; Thence along the arc of said curve a distance of 215.59 feet; Thence N.02°26'46"W. a distance of 49.96 feet; Thence S.87°36'06"W. a distance of 114.68 feet; Thence N.02°24'23"W, a distance of 124.98 feet; Thence S.87°35'16"W. a distance of 419.94 feet; Thence N.02°36'22"W. a distance of 6.15 feet; Thence S.87°30'09"W. a distance of 99.95 feet to a point on the East line of Block F of the aforementioned SILVER SPRINGS WOODS subdivision, said point also being 131.00 feet north of the SE corner of Lot 14 of said Block F; Thence N.02°24'32"W. and along the East line of SILVER SPRINGS WOODS subdivision a distance of 1008.48 feet to a point on the north right-of-way line of SE 20th Lane, said point also being the SE corner of Lot

18, Block E of the aforementioned subdivision; Thence N.87°35'28"E. a distance of 420.00 feet; Thence N.02°25'07"W. a distance of 415.00 feet; Thence S.87°35'28"E. a distance of 420.00 feet to a point on the East line of the aforementioned Block E, SILVER SPRINGS WOODS; Thence N.02°25'07"W. and along the East line of said Block E and TRACT "B" a distance of 1014.56 feet to the Point of Beginning. Said parcel lying and being situated in the NE and SE 1/4's of Section 24 and the NE 1/4 of Section 25, both in Township 15 South, Range 24 East, Marion County, Florida.

Parcel Identification Number: **32651-000-01**

Subject to all reservations, covenants, conditions, restrictions and easements of record and to all applicable zoning ordinances and/or restrictions imposed by governmental authorities, if any.

Together with all the tenements, hereditaments and appurtenances thereto belonging or in any way appertaining.

To Have and to Hold, the same in fee simple forever.

And the grantor hereby covenants with said grantee that the grantor is lawfully seized of said land in fee simple; that the grantor has good right and lawful authority to sell and convey said land; that the grantor hereby fully warrants the title to said land and will defend the same against the lawful claims of all persons whomsoever; and that said land is free of all encumbrances except taxes accruing subsequent to December 31st of 2020.

In Witness Whereof, the grantor has hereunto set their hand(s) and seal(s) the day and year first above written.

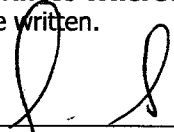

Schantz Scott

Signed, sealed and delivered in our presence:

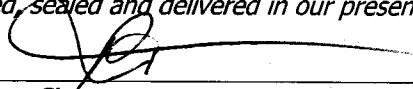

Witness Signature
Paul E Beatty

Print Name

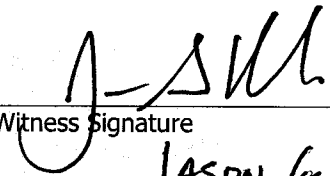

Witness Signature
JASON G. KUNO

Print Name

State of OREGON

County of CLATSOP

The Foregoing Instrument Was Acknowledged before me by means of physical presence or online notarization, on OCTOBER 15, 2021, by **Schantz Scott**.

J-GK
Notary Public
JASON G. KUNOE
(Printed Name)

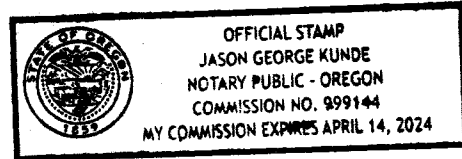

My Commission expires: April 14, 2024

Personally Known OR Produced Identification
Type of Identification Produced a valid driver's license

{Notarial Seal}



ENVIRONMENTAL CORPORATION OF AMERICA

ENVIRONMENTAL | GEOTECHNICAL | WETLANDS | ECOLOGY | CULTURAL RESOURCES

Geotechnical Investigation

FL-01106 Silver Springs

SE 24th Street
Silver Springs, Marion County,
Florida

ECA Project No. 26-000203

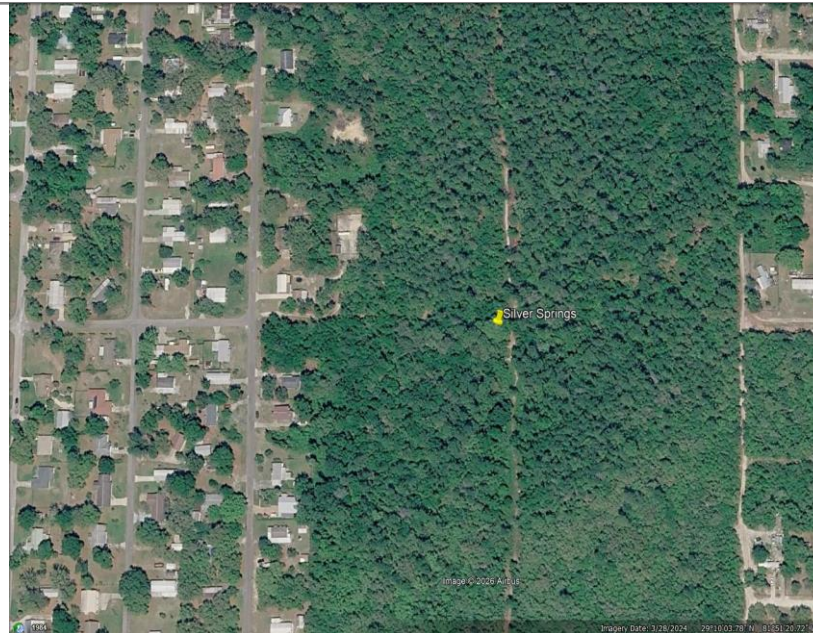

SUBMITTED TO:

Skyway Towers, LLC
3637 Madaca Lane
Tampa, FL 33618

PREPARED BY:

Environmental Corporation of America
1375 Union Hill Industrial Court, Suite A
Alpharetta, GA 30004



ENVIRONMENTAL CORPORATION OF AMERICA

ENVIRONMENTAL | GEOTECHNICAL | WETLANDS | ECOLOGY | CULTURAL RESOURCES

February 27, 2026

Skyway Towers, LLC
3637 Madaca Lane
Tampa, FL 33618

Attention: Mr. Hank Haynes

**Subject: Geotechnical Investigation Report
FL-01106 Silver Springs
SE 24th Street
Silver Springs, Marion County, Florida
ECA Project No. 26-000203**

Dear Mr. Haynes:

Environmental Corporation of America (ECA) is pleased to submit this report of our geotechnical investigation for the proposed project. Our services were provided as authorized by Skyway Towers, LLC, Inc using an email approval dated January 29, 2026.

This report presents a review of the information provided to us, a description of the site and subsurface conditions, and our recommendations. The appendices contain a Site Location Map, a Boring Location Plan, a Boring Log, and Laboratory Earth Resistivity Test Data.

We will be happy to discuss our recommendations with you and look forward to providing the additional studies or services necessary to complete this project. We appreciate the opportunity to be of service. Please call us with any questions at (770) 667-2040.

Sincerely,
Environmental Corporation of America

A handwritten signature in blue ink, appearing to read 'Athulya', is written over a horizontal line.

Athulya Balakrishnan, P.E.
Geotechnical Engineer
State of Florida P.E. # 97346

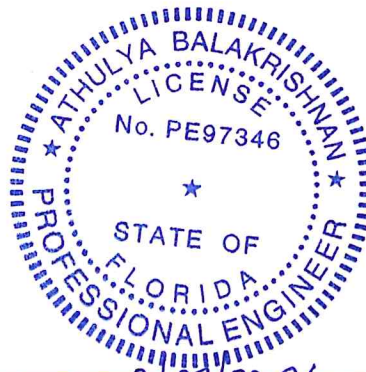

A handwritten signature in blue ink, appearing to read 'Marvin G. Webster', is written over a horizontal line.

Marvin G. Webster
President

Purpose and Scope of Work

The purpose of this investigation was to obtain specific subsurface data at the project location and to provide geotechnical related parameters for the design and construction of the foundations for a proposed monopole tower.

Our scope of work included the following:

- One (1) soil test boring was drilled to a depth of 60 feet below ground surface (bgs).
- Figure 1 shows the Site Location Map. Figure 2 shows the Boring Location Plan.
- Standard penetration tests (SPTs) were conducted to obtain soil samples and SPT N-values, in accordance with ASTM D-1586.
- The depth to groundwater, if any, was measured in the boring after drilling was completed.
- The soil samples were visually classified in accordance with ASTM D-2488 and a boring log was prepared. Natural moisture content (WC_N) tests were performed on a selected number of soil samples in accordance with ASTM D-2216.
- Unconfined compressive strength (q_u) index tests were performed using a pocket penetrometer test or the spring tester test (whenever possible).
- The soil conditions were evaluated by a registered professional engineer and this geotechnical report was prepared with our recommendations.

We have recommended design parameters and settlements based on the SPT N-values, an examination of the soil samples, and our experience with similar soil conditions and structures.

Project Information

We were provided with a set of construction drawings prepared by B+T Group and dated December 29, 2025. The proposed tower would be located near SE 24th Street, Silver Springs, Marion County, Florida.

We understand that plans include constructing a 125-foot-tall monopole tower, approximately as shown in Figure 2. We assume that the equipment building/cabinet will be a prefabricated structure supported on a perimeter grade beam, spread footing or turndown slab. The project also includes the construction of a 30-foot wide ingress/egress utility easement.

Mr. Hank Haynes
Page 3

Field Drilling Work

The field clearing and drilling work was conducted on February 16, 2026. Information obtained from the boring log was used to help us evaluate the subsurface conditions and to assist in formulating our recommendations. The site was staked at the time of our field visit.

Subsurface Soil Conditions (Boring B-1)

In general, soil conditions encountered at the site consisted of very loose to loose silty Sand (SM) to an approximate depth of 4 feet, underlain very stiff to very hard Clay (CL) to an approximate depth of 13.5 feet, underlain by medium dense to very dense silty Sand (SM) to an approximate depth of 33.5 feet, underlain by Weathered Limestone rock fragments manually described as medium dense to dense clayey Sand (Weathered Limestone) to an approximate depth of 43.5 feet, underlain by medium dense to very dense well graded Sand (SW) to the full depth drilled of 60 feet bgs.

Soil Profile Depth (ft)		Type of Soils (Soil Manual Classification)	*Soil Symbols	SPT N-Values bpf (blows per foot)
0	4	Very loose to loose silty Sand	SM	2 to 7
4	13.5	Very stiff to very hard sandy Clay	CL	16 to 63
13.5	33.5	Medium dense to very dense silty Sand	SM	28 to 70
33.5	43.5	Weathered Limestone manually described as medium dense to dense clayey Sand	Weathered Limestone	26 to 40
43.5	50	Medium dense to very dense well graded Sand	SW	22 to Over 50
*Soil symbols are based in the Unified Soil Classification System (USCS).				

The encountered upper sandy layer is very loose to loose in terms of relative density. Between the depths 4 and 13.5 feet, the encountered clay layers are very stiff to very hard in consistency with estimated unconfined compressive strength measurements between 4,000 and 8,000 psf. The encountered silty Sand weathered limestone and well graded sand layers below 13.5 feet are medium dense to very dense in terms of relative density. Natural moisture (WC_N) content measurements were conducted on selected soil samples and ranged between 1.4% to 18.0%. A final boring log is shown in Appendix B.

Groundwater Level Condition

At time of drilling (ATD), a groundwater level was encountered at a depth of 10 feet. It should be noted that groundwater level observations made within mostly cohesive soils during drilling could be misleading. It should be anticipated that the groundwater level will fluctuate due to seasonal climatic changes. To determine actual groundwater level measurements, groundwater levels should be measured using observation wells installed for prolonged periods.

Mr. Hank Haynes
Page 4

Laboratory Electrical Resistivity Test

A laboratory resistivity value of 63,056 ohms-cm was reported. A table with the laboratory test data is shown in Appendix C. It should be noted that the soil samples were saturated for this testing procedure. Based on the laboratory test results, most of the soil is rated “Non-Corrosive”.

Foundation Construction Recommendations

The subsurface conditions are suitable for the support of the proposed tower using either a shallow foundation system or a deep foundation system.

Deep Foundation System

Based on our review of the subsurface soil conditions encountered in the boring, we offer the following average soil parameters for the design of a proposed drilled shaft.

Boring Depth (feet)		*Unit Weight γ_{wet} / γ_b (pcf)	Friction Angle ϕ (deg)	Soil Cohesion C_u (psf)	K_p	Allowable Skin Friction f_s (psf)	Allowable Bearing Pressure q_{ALL} (psf)	Soil Modulus K_H (pci)
0	4	100	26	0	2.56	-	-	-
4	6	110	0	2,000	1.00	450	-	125
6	13	115 / 53	0	4,000	1.00	590	-	205
13	18	115 / 53	32	0	3.25	215	-	165
18	33	120 / 58	34	0	3.54	325	5,000	205
33	38	120 / 58	34	0	3.54	425	7,500	315
38	43	125 / 63	32	0	3.25	410	6,000	250
43	60	125 / 63	36	0	3.85	645	10,000	415

Notes: A safety factor of 2 is used for allowable skin friction (f_s). A safety factor of 3 is used for allowable soil bearing pressure (q_{ALL}). *Below the groundwater level designer should consider the buoyant unit weight (γ_b) = $\gamma_{wet} - \gamma_{water}$.
Active earth pressure coefficient $K_A = \tan^2(45 - \phi/2) = 1/K_p$.
At rest earth pressure coefficient $K_O = 1 - \sin(\phi)$.

The proposed drilled shaft should be designed using a combination of point bearing and friction forces. Total drilled shaft foundation settlement should be limited to 1-inch. Final shaft diameter (D) and embedment length (L) will depend upon final tower loading conditions. For these foundations ECA recommends a minimum concrete strength (f'_c) of 4,000 psi (pounds per square inch).

Shallow Foundation System

For the case of a pad and pier foundation, the soils are capable of a maximum net allowable soil bearing pressure (q_{ALL}) of 4,500 psf at a minimum embedment depth (D_f) of 6 feet below existing grade elevation. Total and differential settlement should be less than 1-inch and ½-inch, respectively. A safety factor of 3 and a wet soil unit weight (γ_{wet}) of 115 pcf were considered for soil bearing computations.

The provided soil bearing pressure assumes the bottom of excavation would be dry and stable. The bottom of excavation should be proof rolled, observed, and inspected prior to placing any concrete. For more details, please refer to our Fill Placement section.

Building Foundations

The proposed equipment building can be supported on a perimeter grade beam, spread footing or turndown slab foundation. For the design of the building foundation the soils are capable of a maximum net allowable soil bearing pressure (q_{ALL}) of 2,000 psf. A minimum depth of foundation (D_f) of 2.0 feet below existing grades elevations should be considered. Total and differential settlements should be less than 1/2-inch and 1/4-inch, respectively.

Ground floor slabs may be designed as conventional slabs on grade over the existing soils or on engineered compacted fill using a Modulus of Subgrade Reaction (K_s) of 85 pci (pounds per cubic inch). The bearing pad should be prepared and compacted prior to placing any concrete. Contractors should verify the Fill Placement section of this report.

Soil Site Class

Based on our site evaluation and the information provided by the 2018 International Building Code and TIA-222-H-2016 to perform a dynamic analysis the project engineer should consider as **Stiff Soil Profile and Site Class D**.

Foundation Excavations

A groundwater level will be encountered during foundation excavation, therefore prospective contractor should consider excavation dewatering. We believe either casing or slurry drilling will be required. However, drilling method should be selected by the contractor based on their experience with similar soil conditions.

The installation of the drilled shaft foundation should be in accordance with FDOT Specification 455-23 (Drilled Shaft Foundations). Based on the unconsolidated nature of the soils existing at the site, the drilled shafts should be installed using the "wet" construction method utilizing either a polymer or bentonite slurry to stabilize the shaft excavation.

To avoid softening of the shallow soils exposed at the foundation bearing level, excavations should not be left open for extended periods prior to placing reinforcing steel and concrete. If rain or freezing weather is expected, excavations should not be completed. Leaving the excavations at least 1-foot above final grade should protect the bearing soils from deterioration.

If the excavation must remain open overnight or if rainfall becomes imminent while the bearing soils are exposed, we recommend that a 2 to 4-inch thick "mud-mat" of "lean" (2,000 psi) concrete be placed on the bearing soils before the placement of reinforcing steel. If the bearing soils are softened by surface water intrusion or exposure, the softened soils must be removed from the foundation excavation bottom immediately prior to placement of concrete.

Mr. Hank Haynes
Page 6

Fill Placement

If required, borrow materials for fill, unless otherwise specified, should consist of essentially granular material (GW, GM, GC, GP, SW, SM or SP Unified Soil Classification System); A-2-4 or better, AASHTO Classification, as approved by the Project Geotechnical Engineer. These should be free from vegetation and should not contain rocks greater than 6 inches in size.

The amount of fill required for this project depends on the planned final grades. Any fill or backfill required to attain finished grade should be placed in layers not exceeding 8- to 10-inch thick lifts and compacted to not less than 95% of the Standard Proctor Maximum dry density, as determined by method (ASTM D-698). The soil moisture content should be close to the optimum moisture content. All required fills should meet the specified compaction criteria.

ECA does not know the capability of the surficial soil to support pavements. However, we suggest that the upper soils be replaced by granular fill in areas of heavy traffic to improve the subgrade support capabilities and moisture sensitivity.

Field density tests should be conducted at routine intervals as the fill is being placed to verify that adequate compaction is achieved. Prior to placing any new fill, any soft or loose near surface soils should be removed and the area proof-rolled with a heavy vehicle or a heavy compaction vibratory roller to confirm that any unsuitable soil conditions have been discovered.

Basis for Recommendations

The subsurface conditions encountered at the boring location is shown on the Boring Log in Appendix B. The Boring Log represents our interpretation of the subsurface conditions based on the field logs and visual examination of field samples by an engineer. The lines designating the interface between various strata on the Boring Log represents the approximate interface locations. In addition, the transition between strata may be gradual. The water level shown on the Boring Log, if any, represents the condition only at the time of our exploration.

The recommendations contained herein are based in part on project information provided to us and only apply to the specific project and site discussed in this report. If the project information section in this report contains incorrect information or if additional information is available, please let us know so that we may review the validity of our recommendations.

Regardless of the thoroughness of a geotechnical investigation, there is always a possibility that conditions between borings will be different from those at specific boring locations and that conditions will not be as anticipated by the designers or contractors. In addition, the construction process may itself alter soil conditions. Therefore, experienced geotechnical personnel should observe and document the construction procedures used and the conditions encountered. Unanticipated conditions and inadequate procedures should be reported to the design team along with timely recommendations to solve any problems created. ECA is best qualified to provide this service based on our familiarity with the project, the subsurface conditions, and the intent of the recommendations and design. We wish to remind you that we will store the soil samples for 30 days. The samples will then be discarded unless you request otherwise.

Mr. Hank Haynes

Page 7

APPENDICES

Appendix A Figures

Appendix B Boring Log

Appendix C Laboratory Earth Resistivity Test Data

APPENDIX A

Figures



Source: USGS Topographic Map: Half Moon Lake, FL (2021).



FL-01106 Silver Springs
SE 24th Street
Silver Springs, Marion County, Florida
Figure 1: Site Location Map



ECA Project #26-000203

APPENDIX B

Boring Log

ATTACHMENT A Application Packet PL SUP-000450-2026

Project: FL-01106 Silver Springs	Environmental Corp of America 1375 Union Hill Industrial Ct. Suite-A Alpharetta, GA 30004 (770) 667-2040	Log of Boring B-1 Sheet 1 of 2
Project Location: Silver Springs, FL		
Project Number: 26-000203		

Date(s) Drilled: 2/16/2026	Logged By: A. Balakrishnan	Checked By: A. Balakrishnan
Drilling Method: Mud Drilling/HSA	Drill Bit Size/Type: 2.25 inches	Total Depth of Borehole: 60 feet bgs
Drill Rig Type: Truck	Drilling Contractor: Old South	Approximate Surface Elevation: 80 feet AMSL
Groundwater Level and Date Measured: 10 feet ATD	Sampling Method(s): SPT	Hammer Data: 140 Lbs hammer, rope and cathead
Borehole Backfill: Cuttings	Location: Silver Springs, Marion County, Florida	











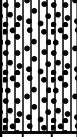

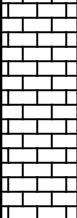
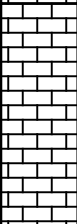
Depth (feet)	Sample Number	Sample Type	Sampling Resistance blows/ft	SPT N Values	Rec (%) / RQD (%)	MATERIAL DESCRIPTION	Material Type	Graphic Log	Water Content, %	qu (tsf)	PH	LL, %	PI, %
0						Light brown, very loose fine silty Sand, dry topsoil 2"	SM		-	-			
1			1-1-1-2	2		Same as above, loose, dry	SM		1.4	-			
2			4-4-3-3	7		Orange, very stiff sandy Clay, damp	CL		-	-			
5			2-3-13-20	16		Same as above, very hard, damp	CL		8.3	-			
4			31-30-33-25	63		Same as above, hard, orange/grey, damp	CL		-	-			
5			28-17-27-38	44									
10						▽							
6			15-14-14	28		Light grey/brown, medium dense silty Sand, damp	SM		9.5	-			
15						Same as above, dense, damp	SM		-	-			
7			14-22-23	45		Same as above, dense, damp	SM		13.5	-			
20													
8			12-19-22	41		Same as above, very dense, light brown, damp	SM		-	-			
25													
9			23-31-39	70									
30													

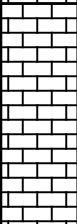
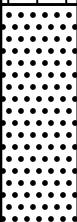
F:\PROJECT\2026proj\26-000200 - 26-000224\26-000203\Boring B-1_FL-01106 Silver Springs_26-000203.bq4[ECA Temp.tpl]

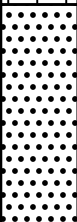

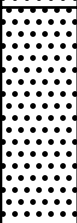
ATTACHMENT A Application Packet PL SUP-000450-2026

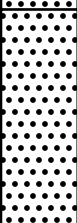
Project: FL-01106 Silver Springs Project Location: Silver Springs, FL Project Number: 26-000203	Environmental Corp of America 1375 Union Hill Industrial Ct. Suite-A Alpharetta, GA 30004 (770) 667-2040	Log of Boring B-1 Sheet 2 of 2
----------------------------------------------------------------------------------------------------------------------------	-------------------------------------------------------------------------------------------------------------------	-------------------------------------------------

Depth (feet)	Sample Number	Sample Type	Sampling Resistance blows/ft	SPT N Values	Rec (%) / RQD (%)	MATERIAL DESCRIPTION	Material Type	Graphic Log	Water Content, %	qu (tsf)	PH	LL, %	PI, %
30						Same as above, very dense, light brown, damp	SM						
35	10		17-19-21	40		Weathered Limestone Rock manually described as dense clayey Sand, wet			16.7	-			
40						Same as above, medium dense, wet							
45	11		12-12-14	26		Same as above, medium dense, wet							
50						Grey/brown, very dense well graded Sand, wet	SW		14.4	-			
55	12		28-20-43	63		Grey/brown, very dense well graded Sand, wet	SW						
60	13		23-26-31	57		Same as above, very dense, light grey, damp	SW						
65	14		36-50/5"	50/5"		Same as above, very dense, light grey, damp	SW		18.0				
70	15		14-12-10	22		Same as above, medium dense, damp	SW						
60	End of Boring at 60 feet.												

F:\PROJECT\2026proj\26-000200 - 26-000224\26-000203\Boring B-1_FL-01106 Silver Springs_26-000203.bg4[ECA Temp.tpl]



ATTACHMENT A Application Packet PL SUP-000450-2026

Project: FL-01106 Silver Springs Project Location: Silver Springs, FL Project Number: 26-000203	Environmental Corp of America 1375 Union Hill Industrial Ct. Suite-A Alpharetta, GA 30004 (770) 667-2040	<h2 style="margin: 0;">Key to Log of Boring</h2> <h3 style="margin: 0;">Sheet 1 of 1</h3>
----------------------------------------------------------------------------------------------------------------------------	-------------------------------------------------------------------------------------------------------------------	-------------------------------------------------------------------------------------------

Depth (feet)	Sample Number	Sample Type	Sampling Resistance blows/ft	SPT N Values	Rec (%) / RQD (%)	MATERIAL DESCRIPTION	Material Type	Graphic Log	Water Content, %	qu (tsf)	PH	LL, %	PI, %
1	2	3	4	5	6	7	8	9	10	11	12	13	14

COLUMN DESCRIPTIONS

- | | |
|-------------------------------------------------------------------------------------------------------------------------------------------------------------------------------------------------------------------------------------------------------------------------------------------------------------------------------------------------------------------------------------------------------------------------------------------------------------------------------------------------------------------------------------------------------------------------------------------------------------------------------------------------------------------------------------------------------------------------------------------------------------------------|------------------------------------------------------------------------------------------------------------------------------------------------------------------------------------------------------------------------------------------------------------------------------------------------------------------------------------------------------------------------------------------------------------------------------------------------------|
| <p>1 Depth (feet): Depth in feet below the ground surface.</p> <p>2 Sample Number: Sample identification number.</p> <p>3 Sample Type: Type of soil sample collected at the depth interval shown.</p> <p>4 Sampling Resistance, blows/ft: Number of blows to advance driven sampler one foot (or distance shown) beyond seating interval using the hammer identified on the boring log.</p> <p>5 SPT N Values: SPT N Values</p> <p>6 Rec (%) / RQD (%): Core Recovery(%) & Rock Quality Designation (%)</p> <p>7 MATERIAL DESCRIPTION: Description of material encountered. May include consistency, moisture, color, and other descriptive text.</p> <p>8 Material Type: Type of material encountered.</p> | <p>9 Graphic Log: Graphic depiction of the subsurface material encountered.</p> <p>10 Water Content, %: Water content of the soil sample, expressed as percentage of dry weight of sample.</p> <p>11 qu (tsf): Unconfined Compression test</p> <p>12 PH : Soil PH Tested</p> <p>13 LL, %: Liquid Limit, expressed as a water content.</p> <p>14 PI, %: Plasticity Index, expressed as a water content.</p> |
|-------------------------------------------------------------------------------------------------------------------------------------------------------------------------------------------------------------------------------------------------------------------------------------------------------------------------------------------------------------------------------------------------------------------------------------------------------------------------------------------------------------------------------------------------------------------------------------------------------------------------------------------------------------------------------------------------------------------------------------------------------------------------|------------------------------------------------------------------------------------------------------------------------------------------------------------------------------------------------------------------------------------------------------------------------------------------------------------------------------------------------------------------------------------------------------------------------------------------------------|

FIELD AND LABORATORY TEST ABBREVIATIONS

- | | |
|----------------------------------------------------------------------------------------------------------------------------------------------|-----------------------------------------------------------------------------------------------------------------------------------------------------------------------------------------------|
| CHEM: Chemical tests to assess corrosivity
COMP: Compaction test
CONS: One-dimensional consolidation test
LL: Liquid Limit, percent | PI: Plasticity Index, percent
SA: Sieve analysis (percent passing No. 200 Sieve)
UC: Unconfined compressive strength test, Qu, in ksf
WA: Wash sieve (percent passing No. 200 Sieve) |
|----------------------------------------------------------------------------------------------------------------------------------------------|-----------------------------------------------------------------------------------------------------------------------------------------------------------------------------------------------|

MATERIAL GRAPHIC SYMBOLS

- | | |
|-------------------------------------------------------------------|-------------------------------------------------------|
| <p> Lean CLAY, CLAY w/SAND, SANDY CLAY (CL)</p> <p> Limestone</p> | <p> Silty SAND (SM)</p> <p> Well graded SAND (SW)</p> |
|-------------------------------------------------------------------|-------------------------------------------------------|

TYPICAL SAMPLER GRAPHIC SYMBOLS

- | | | |
|-----------------------------------------------------------------------------------------------------------|----------------------------------------------------------------------------------------------------------------------------|-------------------------------------------------------------------------------------------|
| <p> Auger sampler</p> <p> Bulk Sample</p> <p> 3-inch-OD California w/ brass rings</p> <p> CME Sampler</p> | <p> Grab Sample</p> <p> 2.5-inch-OD Modified California w/ brass liners</p> <p> NQ Rock sampler</p> <p> Pitcher Sample</p> | <p> 2-inch-OD unlined split spoon (SPT)</p> <p> Shelby Tube (Thin-walled, fixed head)</p> |
|-----------------------------------------------------------------------------------------------------------|----------------------------------------------------------------------------------------------------------------------------|-------------------------------------------------------------------------------------------|

OTHER GRAPHIC SYMBOLS

- Water level (at time of drilling, ATD)
- Water level (after waiting, AW)
- Minor change in material properties within a stratum
- Inferred/gradational contact between strata
- Queried contact between strata

GENERAL NOTES

- 1: Soil classifications are based on the Unified Soil Classification System. Descriptions and stratum lines are interpretive, and actual lithologic changes may be gradual. Field descriptions may have been modified to reflect results of lab tests.
- 2: Descriptions on these logs apply only at the specific boring locations and at the time the borings were advanced. They are not warranted to be representative of subsurface conditions at other locations or times.

F:\PROJECT\2026proj\26-000200 - 26-000224\26-000203\Boring B-1_FL-01106 Silver Springs_26-000203.bq4[ECA Temp.tpl]

APPENDIX C

Laboratory Earth Resistivity Test Data

APPENDIX C

Laboratory Earth Resistivity Test Data per ASTM G-57

Site Name: FL-01106 Silver Springs

ECA Project #: 26-000203

Test Date: February 26, 2026

Test No.	Lab Meter Reading (R)	Calculated Resistivity (Ohms-cm)
Test Trial #1	48.060	63,030
Test Trial #2	48.070	63,043
Test Trial #3	48.090	63,069
Test Trial #4	48.100	63,082
*Average Reported Lab ER Value		63,056
*The lab resistivity test was performed using mixed samples within the upper 6 feet.		