

PARCEL NO.	SHEET NO.	NAME	AREA TAKEN	REMAINDERS		COMMENTS
				LEFT	RIGHT	
113	23, 28	PFJ SOUTHEAST LLC, A DELAWARE LIMITED LIABILITY COMPANY	13,448 SQ FT	19,031 AC	N/A	FEE SIMPLE
114	28	BOWMAN 2000, LLC, A MARYLAND LIMITED LIABILITY COMPANY	9,720 SQ FT	12,730 AC	N/A	FEE SIMPLE
115	28	ALLTEL COMMUNICATIONS, INC., A DELAWARE CORPORATION	2,970 SQ FT	8,324 AC	N/A	FEE SIMPLE
116	28	HEIRS AND BENEFICIARIES OF THE ESTATE OF KATHY BROWN JAMES, DECEASED	924 SQ FT	3,237 AC	N/A	FEE SIMPLE
117	23, 28	CALAMART, LLC, A FLORIDA LIMITED LIABILITY COMPANY	1,260 SQ FT	N/A	2,498 AC	FEE SIMPLE
118	28	PFJ SOUTHEAST LLC, A DELAWARE LIMITED LIABILITY COMPANY	3,138 SQ FT	N/A	N/A	FEE SIMPLE (ABBREVIATED PARENT TRACT)
700	28	BOWMAN 2000, LLC, A MARYLAND LIMITED LIABILITY COMPANY	1,820 SQ FT	SEE PARCEL 114	N/A	TEMPORARY CONSTRUCTION EASEMENT
701	28	PFJ SOUTHEAST LLC, A DELAWARE LIMITED LIABILITY COMPANY	1,323 SQ FT	SEE PARCEL 118	N/A	TEMPORARY CONSTRUCTION EASEMENT

LINE DATA					
LINE	BEARING	DISTANCE	LINE	BEARING	DISTANCE
L1	N00°12'04"E	8.00'(C)	L15	N39°47'53"W	7.71'(C)
L2	S89°47'56"E	25.00'(C)	L16	S00°12'04"W	9.10'(C)
L3	S00°12'04"W	14.50'(C)	L17	N89°47'56"W	24.10'(C)
L4	S00°12'04"W	20.00'(C)	L18	S00°12'04"W	12.90'(C)
L5	N44°45'59"E	69.48'(C)	L19	N89°47'56"W	21.71'(C)
L6	S00°20'08"W	49.50'(C)	L20	S53°25'08"W	20.22'(C)
L7	N00°12'04"E	45.50'(C)	L21	N90°00'00"W	17.58'(C)
L8	S89°47'56"E	40.00'(C)	L22	N00°00'00"E	14.56'(C)
L9	S00°12'04"W	45.50'(C)	L23	S90°00'00"E	11.22'(C)
L10	S89°47'56"E	60.00'(C)	L24	N62°28'46"E	15.41'(C)
L11	N00°20'08"E	49.50'(C)	L25	N89°47'56"W	42.26'(C)
L12	N89°47'56"W	49.73'(C)	L26	N00°12'04"E	4.00'(C)
L13	N42°50'36"W	13.14'(C)	L27	S89°47'56"E	23.88'(C)
L14	N22°02'10"E	5.55'(C)	L28	S45°00'00"E	17.09'(C)
			L29	S00°12'04"W	11.53'(C)

END R/W PROJ.
S.R. 326
STA 720+99.73
FND NLD "FDOT LB 8053"
N = 1793399.4759
E = 597600.9403

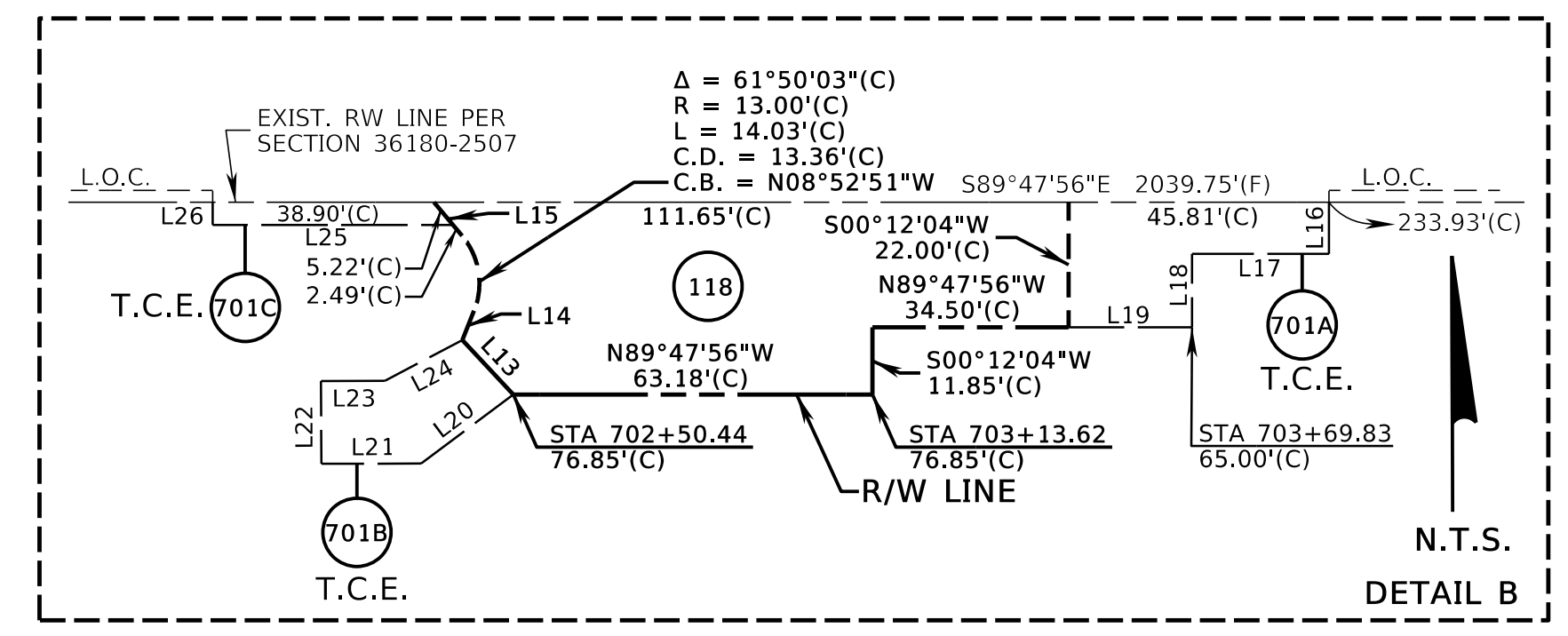
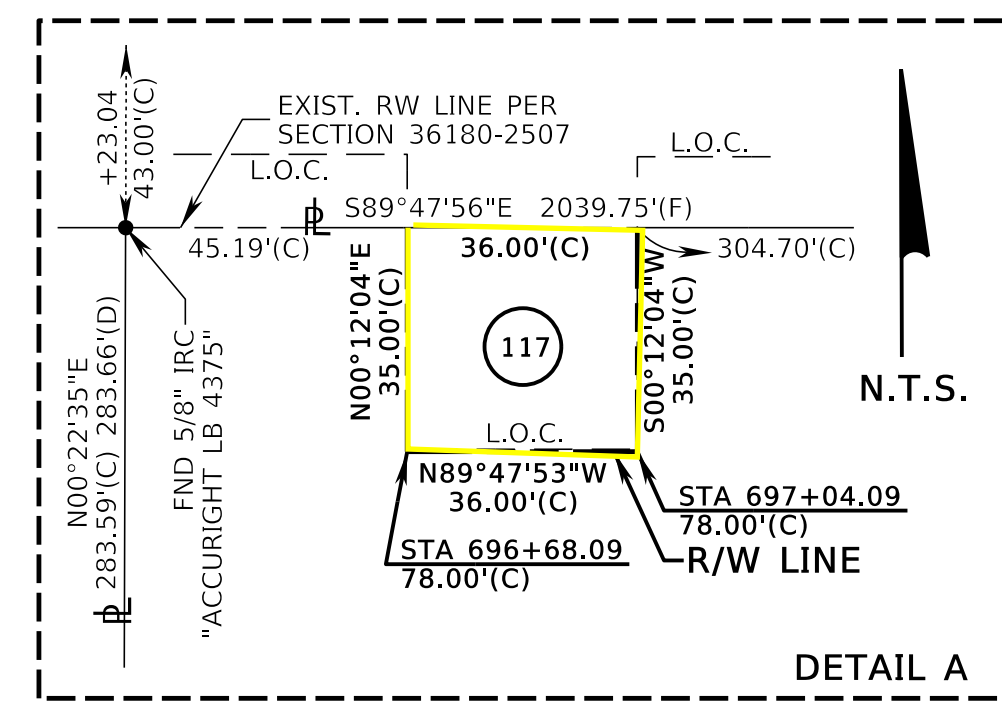

TOWNSHIP 14 SOUTH, RANGE 21 EAST

THIS MAP IS NOT A SURVEY
SEE SHEET 1 FOR GENERAL NOTES AND LEGEND
S.R. 93 (I-75) FROM S.R. 200 TO NORTH OF S.R. 326